



(12) **UK Patent** (19) **GB** (11) **2 344 606** (13) **B**

(45) Date of publication: **13.08.2003**

(54) Title of the invention: **Forming a wellbore casing by expansion of a tubular member**

(51) Int Cl⁷: **E21B 33/14 17/08 43/10**

(21) Application No: **9926449.1**

(22) Date of Filing: **08.11.1999**

(30) Priority Data:
(31) **60111293** (32) **07.12.1998** (33) **US**

(60) Parent of Application No(s)
0229382.7, 0229379.3, 0229377.7 under
Section 15(4) of the Patents Act 1977

(43) Date A Publication: **14.06.2000**

(52) UK CL (Edition V):
E1F FAC FAC9 FJT FJU FLA

(56) Documents Cited:
GB 2347446 A GB 2329918 A
GB 2326896 A GB 2305682 A
GB 2115860 A WO 2000/077431 A
WO 1999/035368 A WO 1998/000626 A
US 6017168 A US 5348095 A

(58) Field of Search:
As for published application 2344606 A viz:
UK CL (Edition R) **B3P PEEB PEQ, E1F FJT**
FJU FLA
INT CL⁷ **E21B 17/00 29/00 33/00 33/03**
33/04 33/10 33/138 33/14 43/10
Other: **Online: EPODOC, JAPIO, WPI**
updated as appropriate

Additional Fields
UK CL (Edition S) **E1F FAC FKU FLT**
INT CL⁷ **E21B 17/02 17/08 17/18 29/10**
43/08
Other: **Online: EPODOC, JAPIO, WPI**

(72) Inventor(s):
Robert Lance Cook
David Paul Brisco
R Bruce Stewart
Lev Ring
Richard Carl Haut
Robert Donald Mack

(73) Proprietor(s):
Shell Internationale Research
Maatschappij B.V.
(Incorporated in the Netherlands)
Department IP/43 Carel Van Bylandtlaan
30, 2596 HR The Hague, Netherlands

(74) Agent and/or Address for Service:
Haseitine Lake & Co
Imperial House, 15-19 Kingsway,
LONDON, WC2B 6UD, United Kingdom

1/26

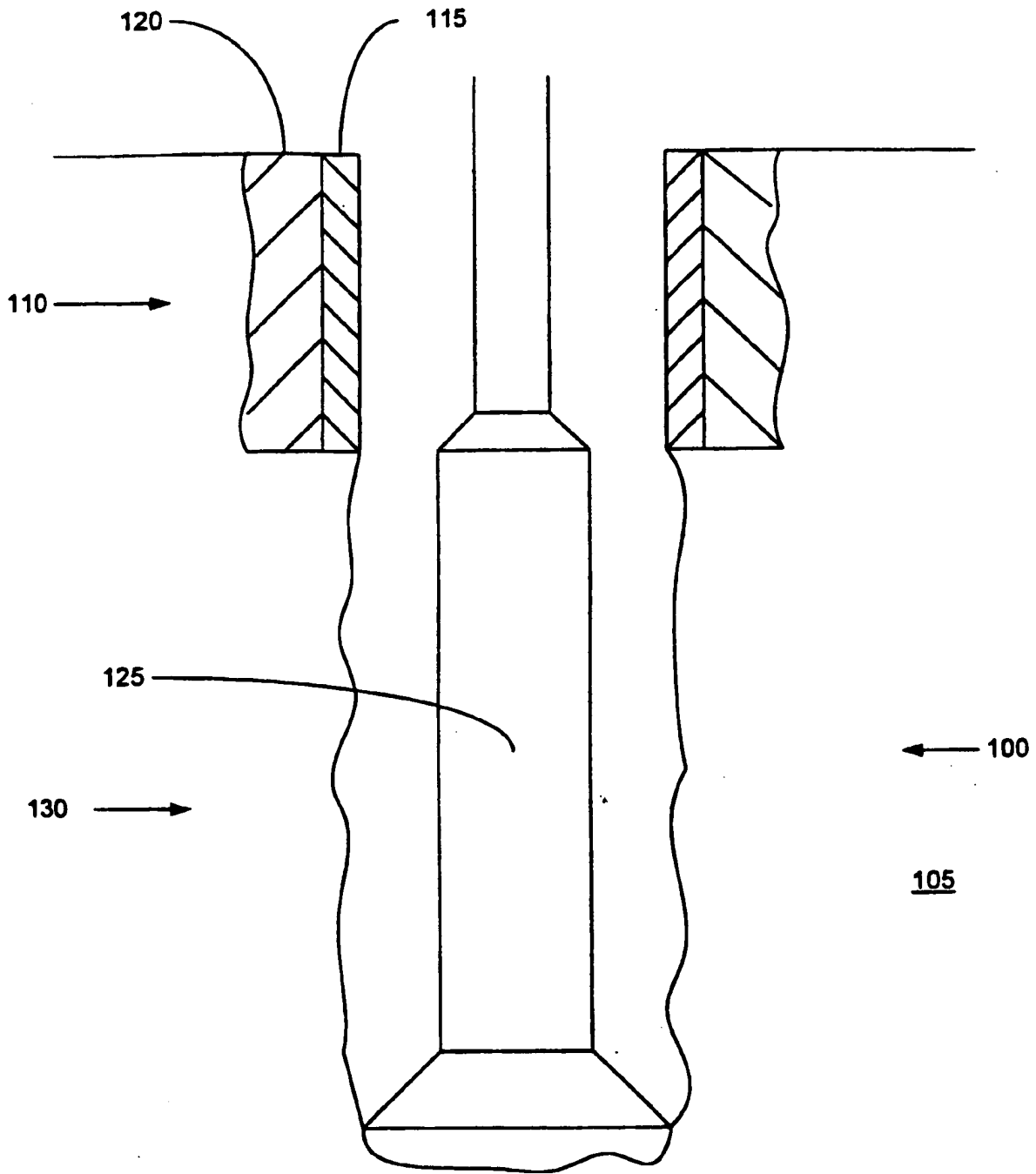

FIGURE 1

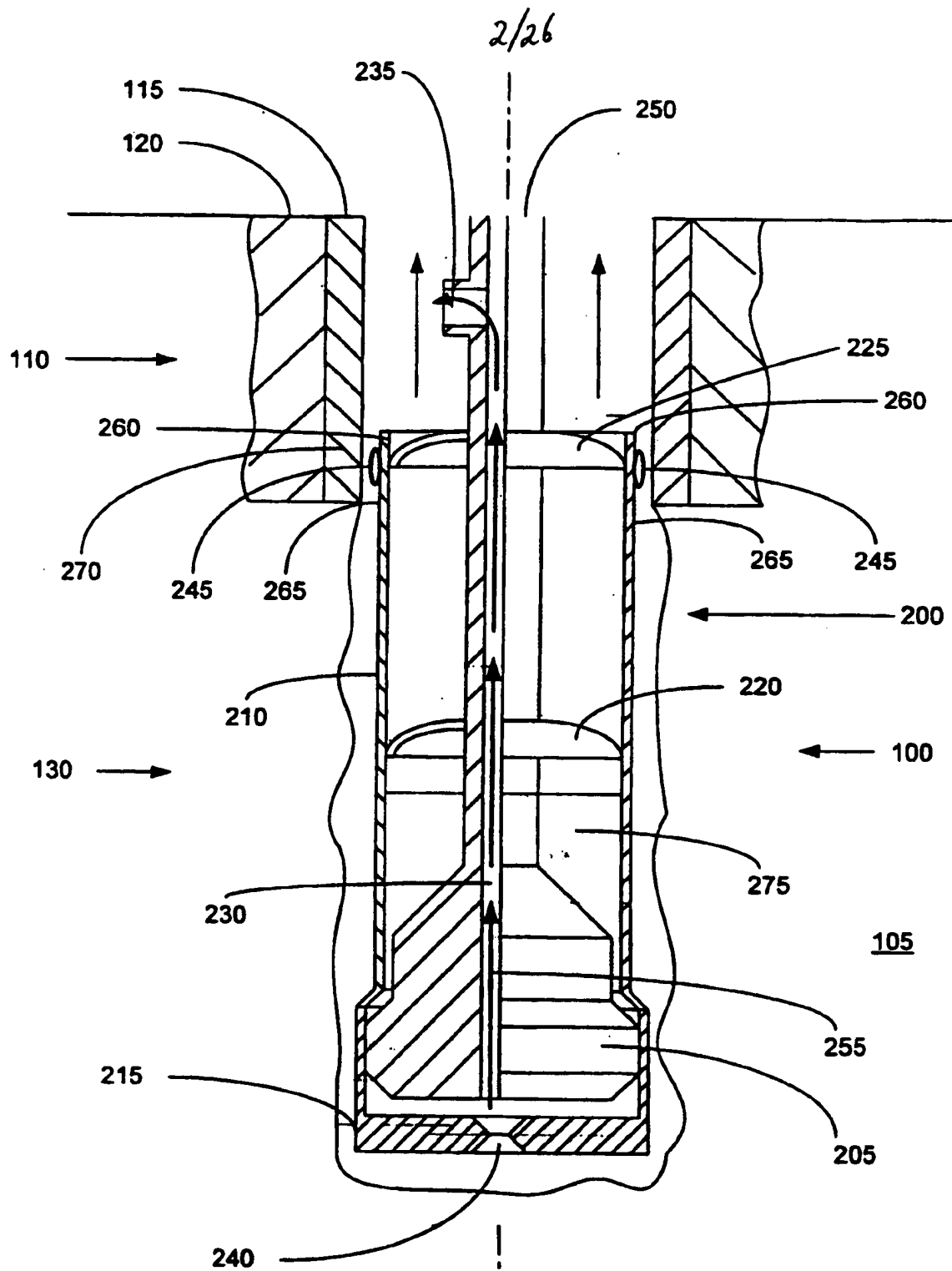

FIGURE 2

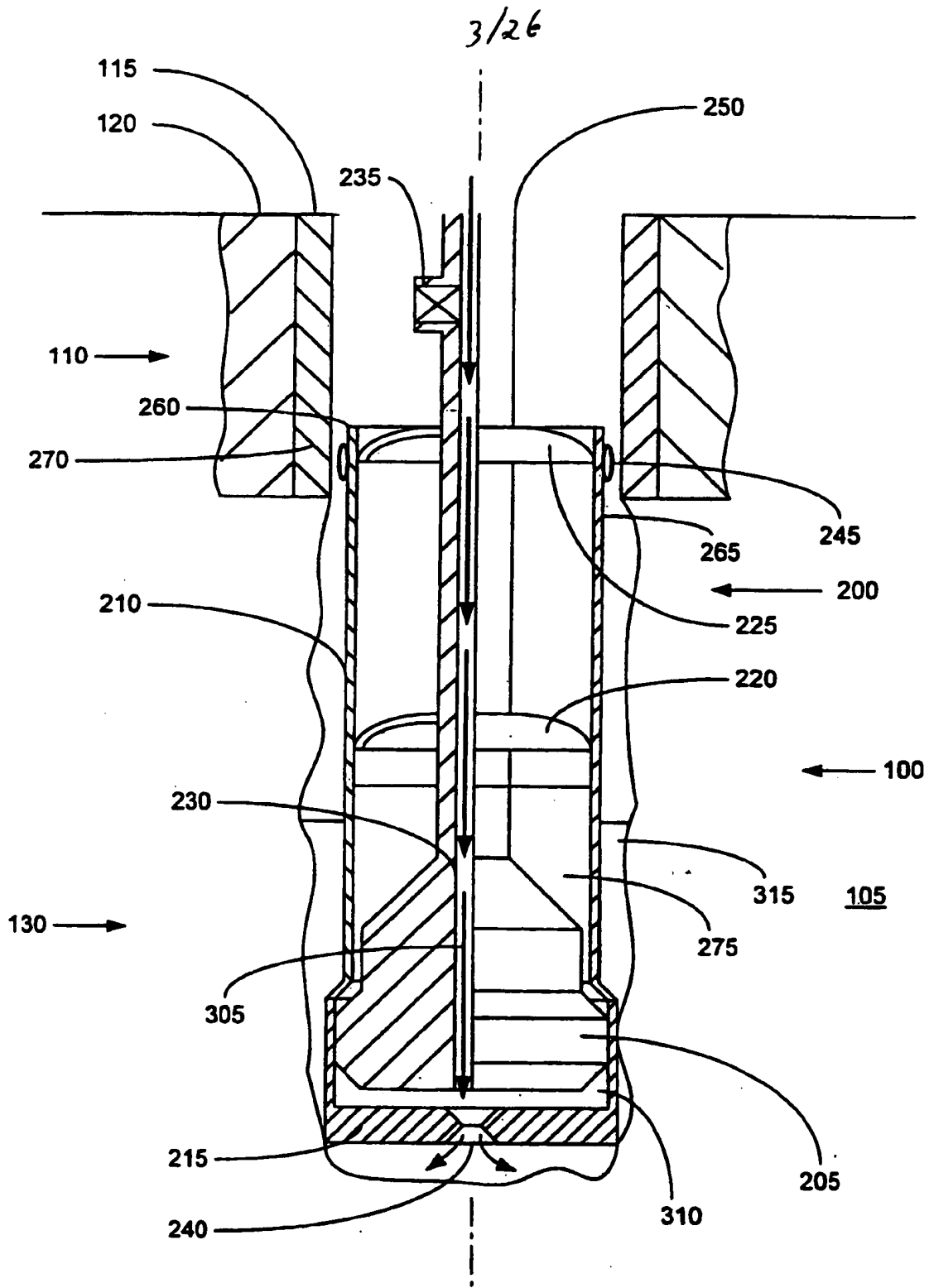

FIGURE 3

4/26

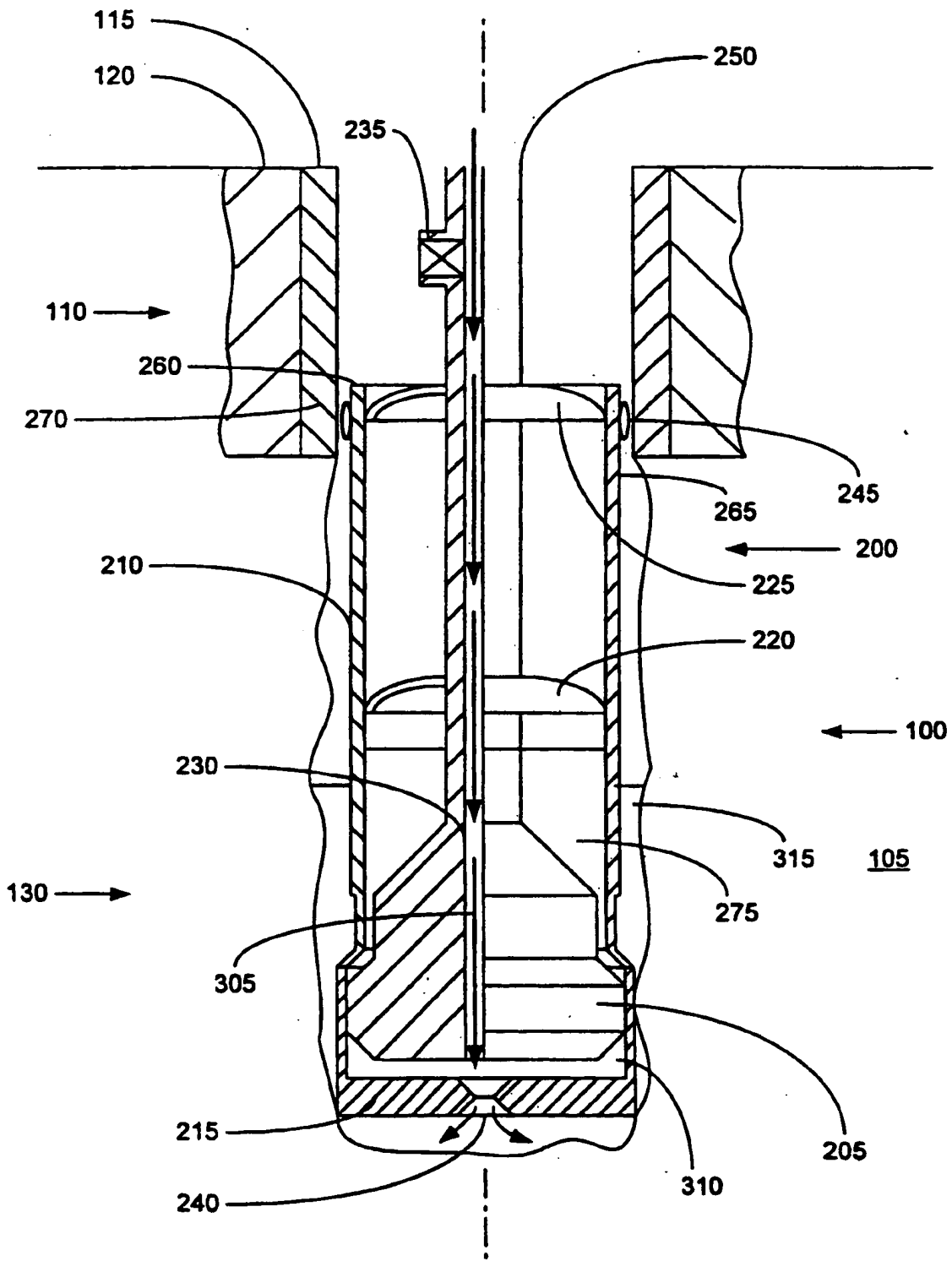

FIGURE 3a

5/26

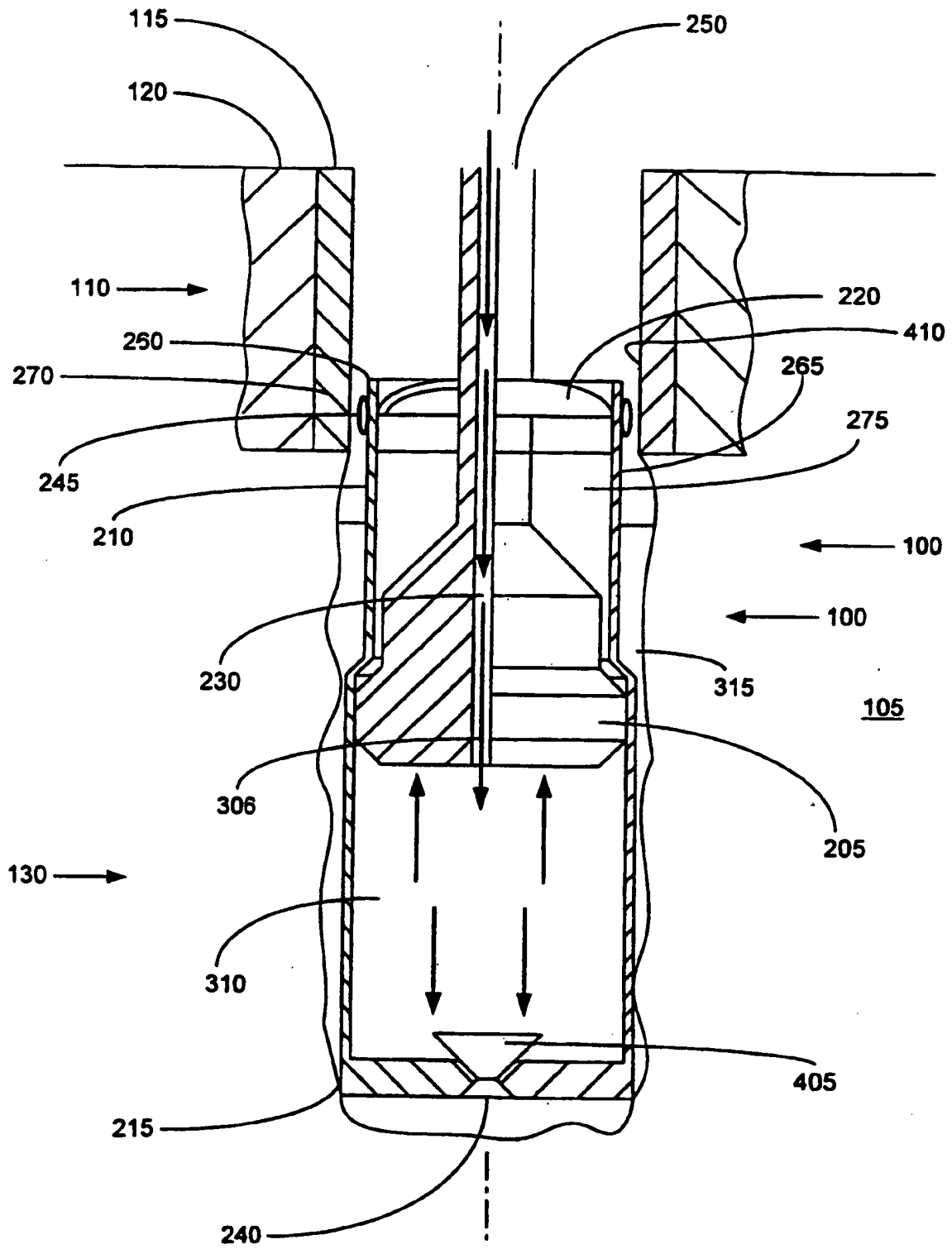

FIGURE 4

6/26

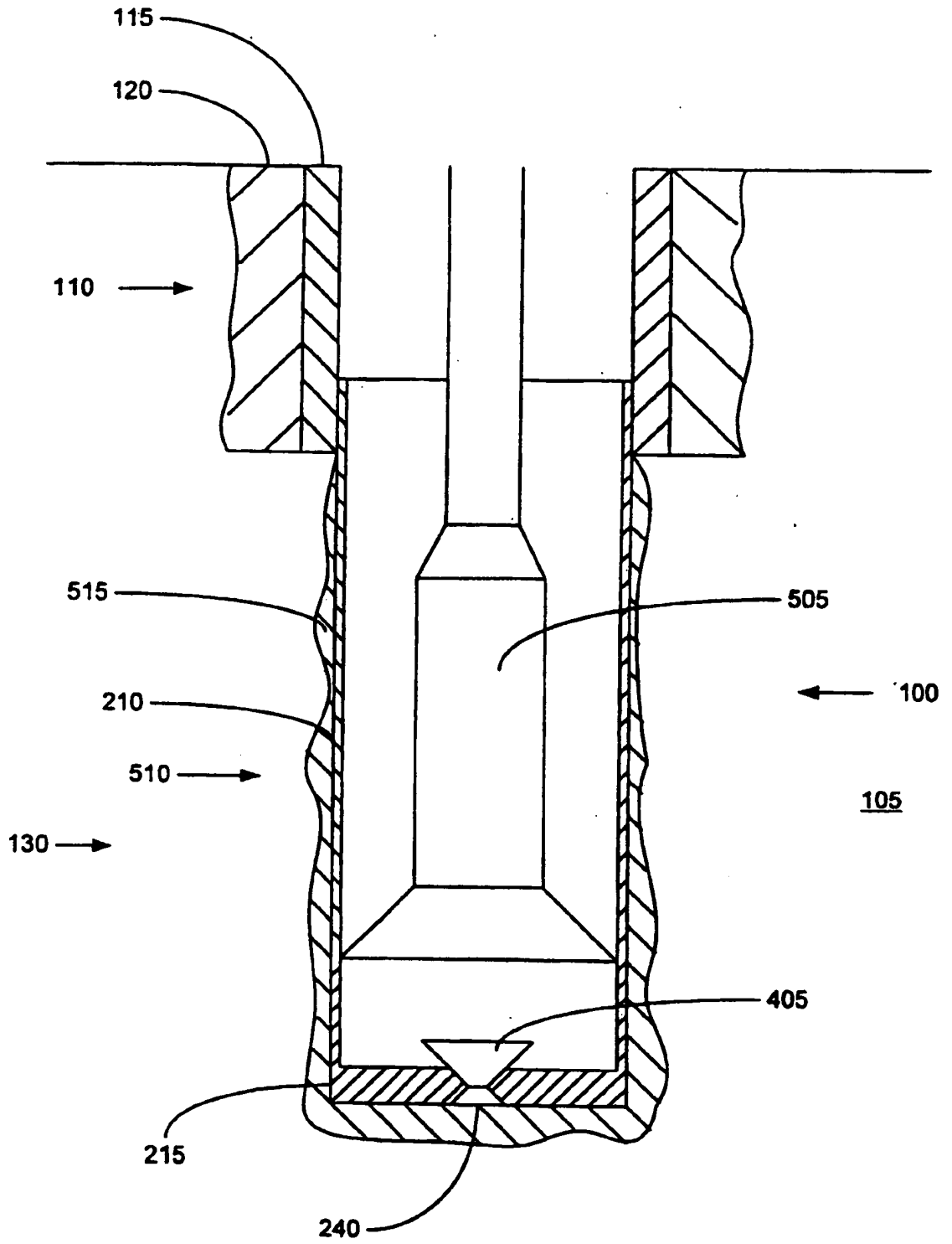

FIGURE 5

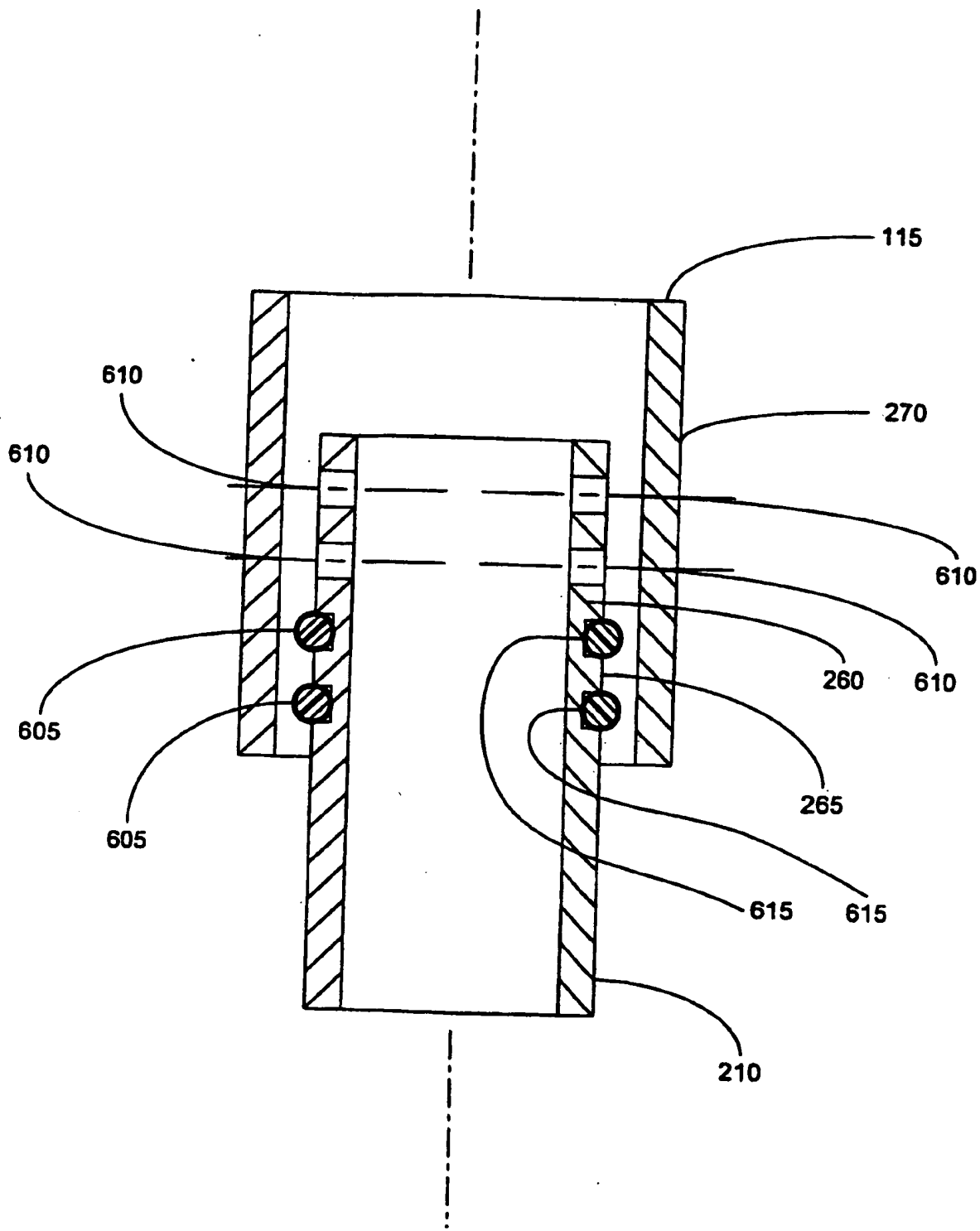

FIGURE 6

8/26

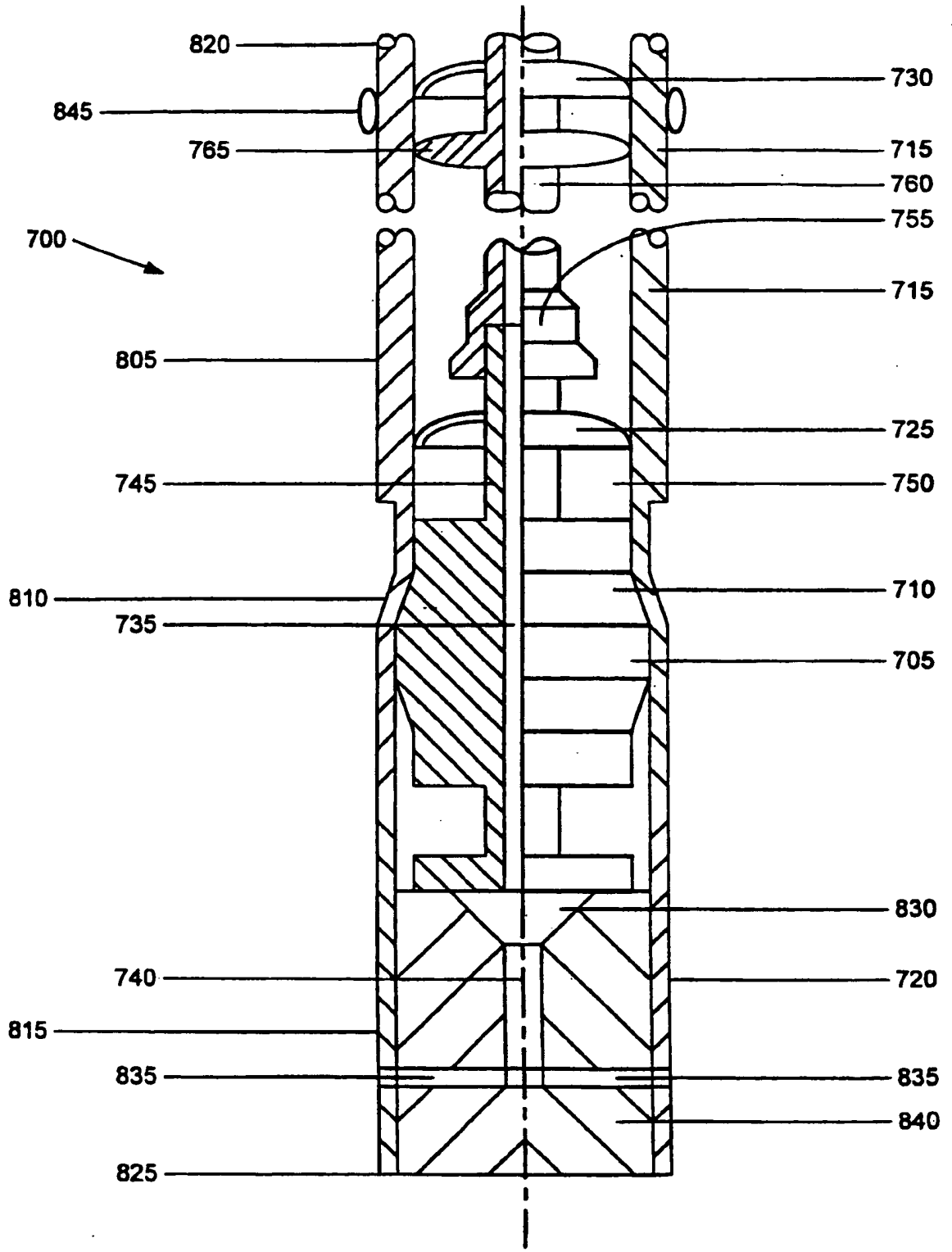

FIGURE 7

9/26

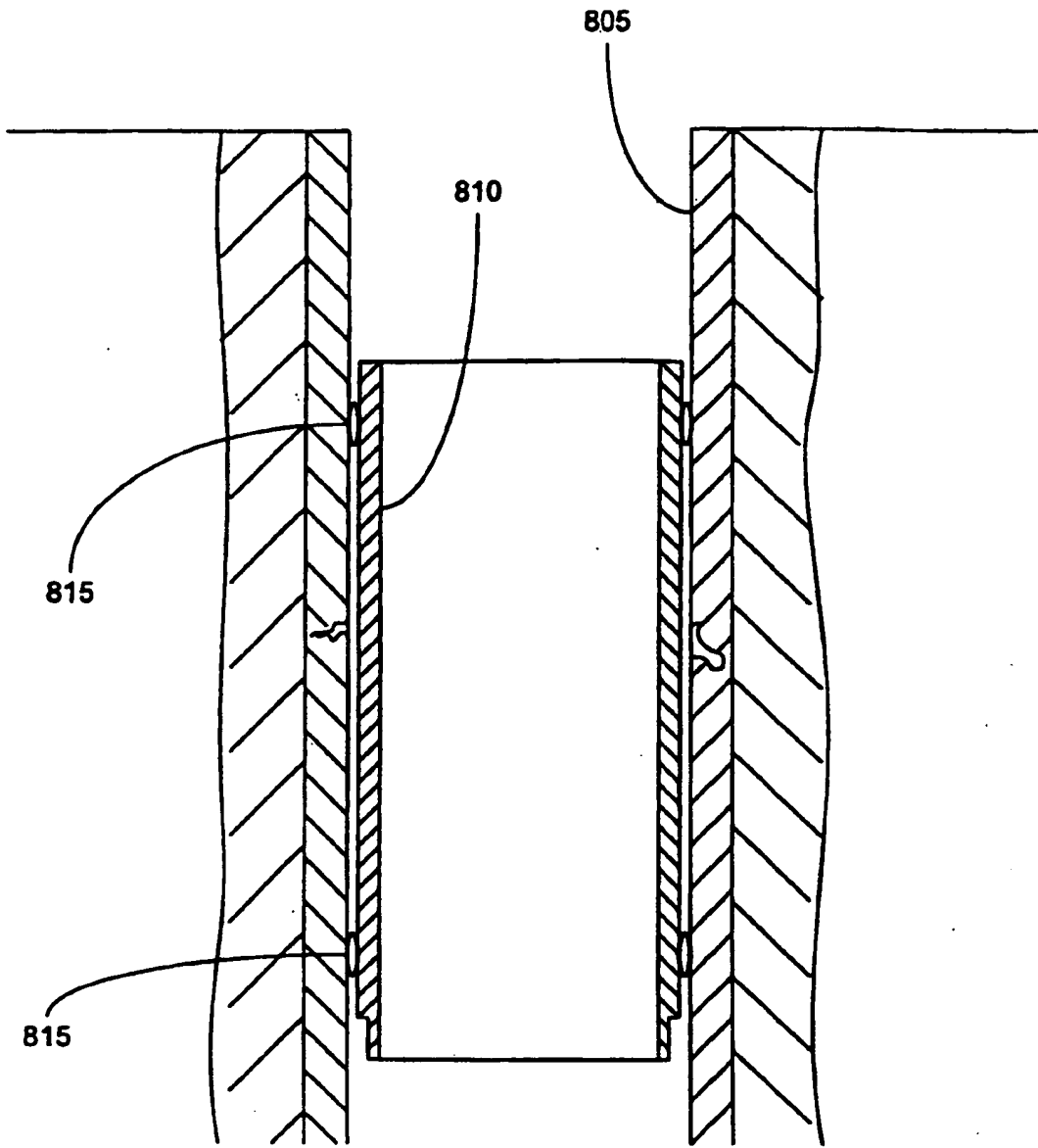

FIGURE 8

10/26

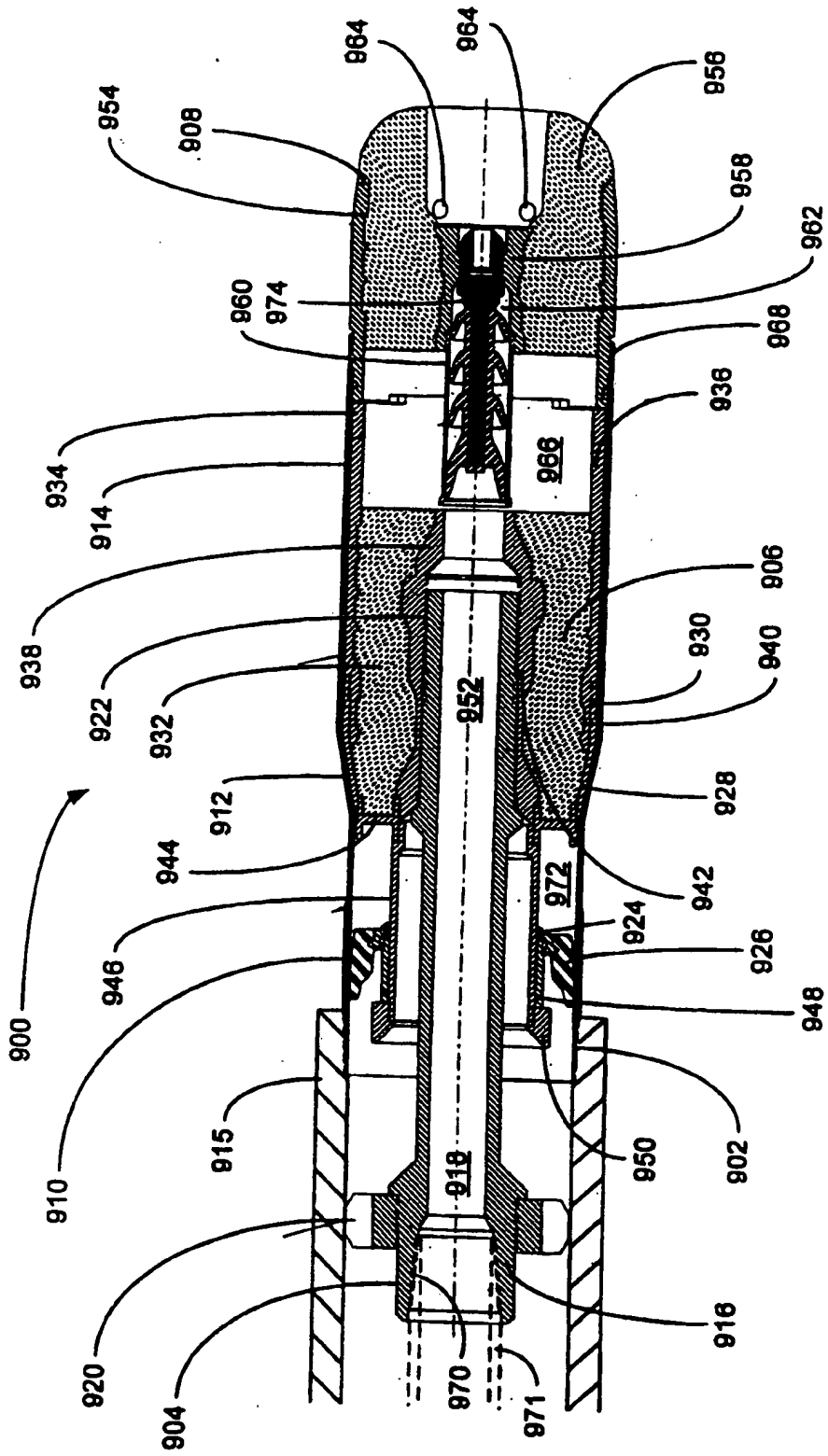

FIGURE 9

11/26

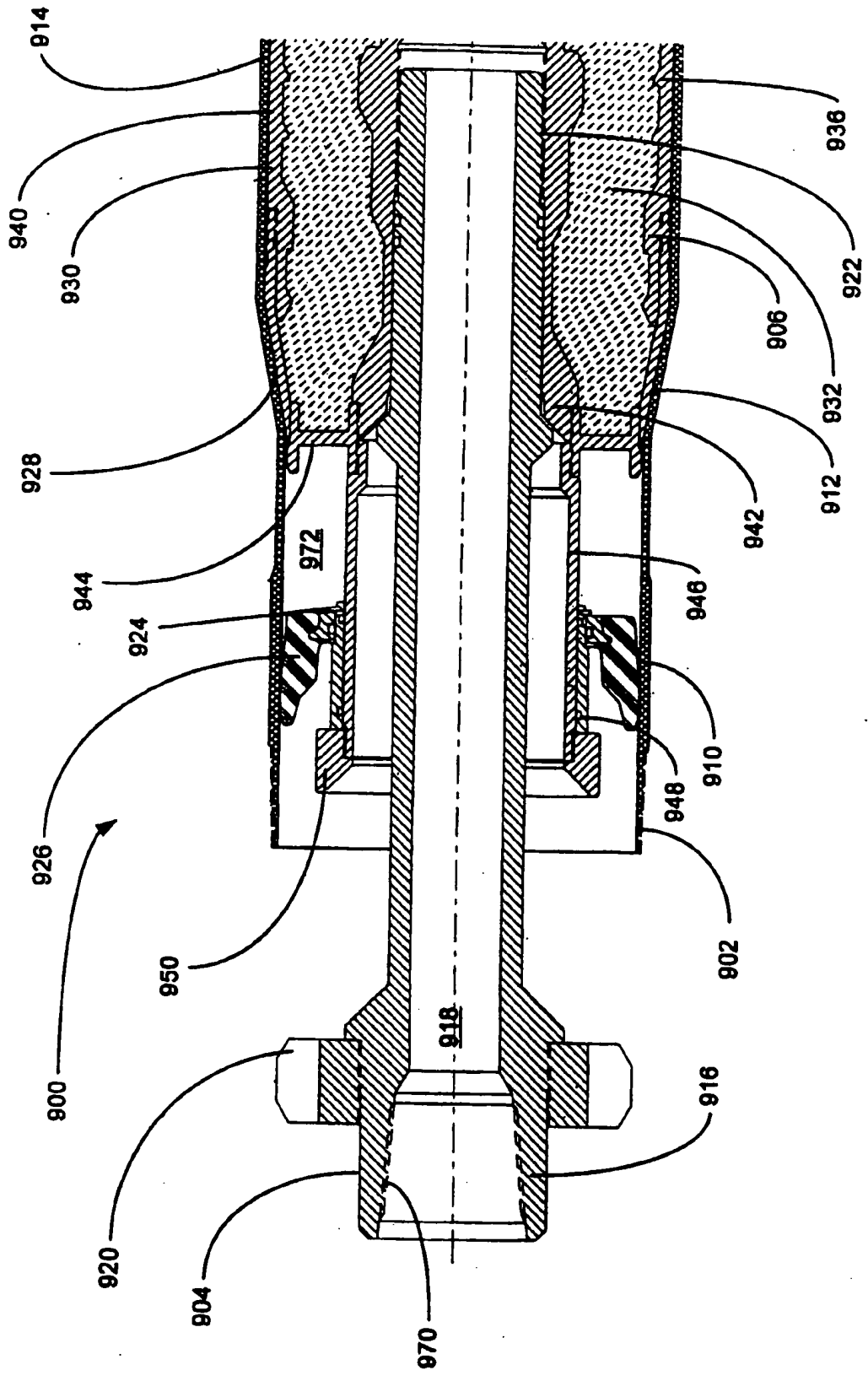

FIGURE 9a

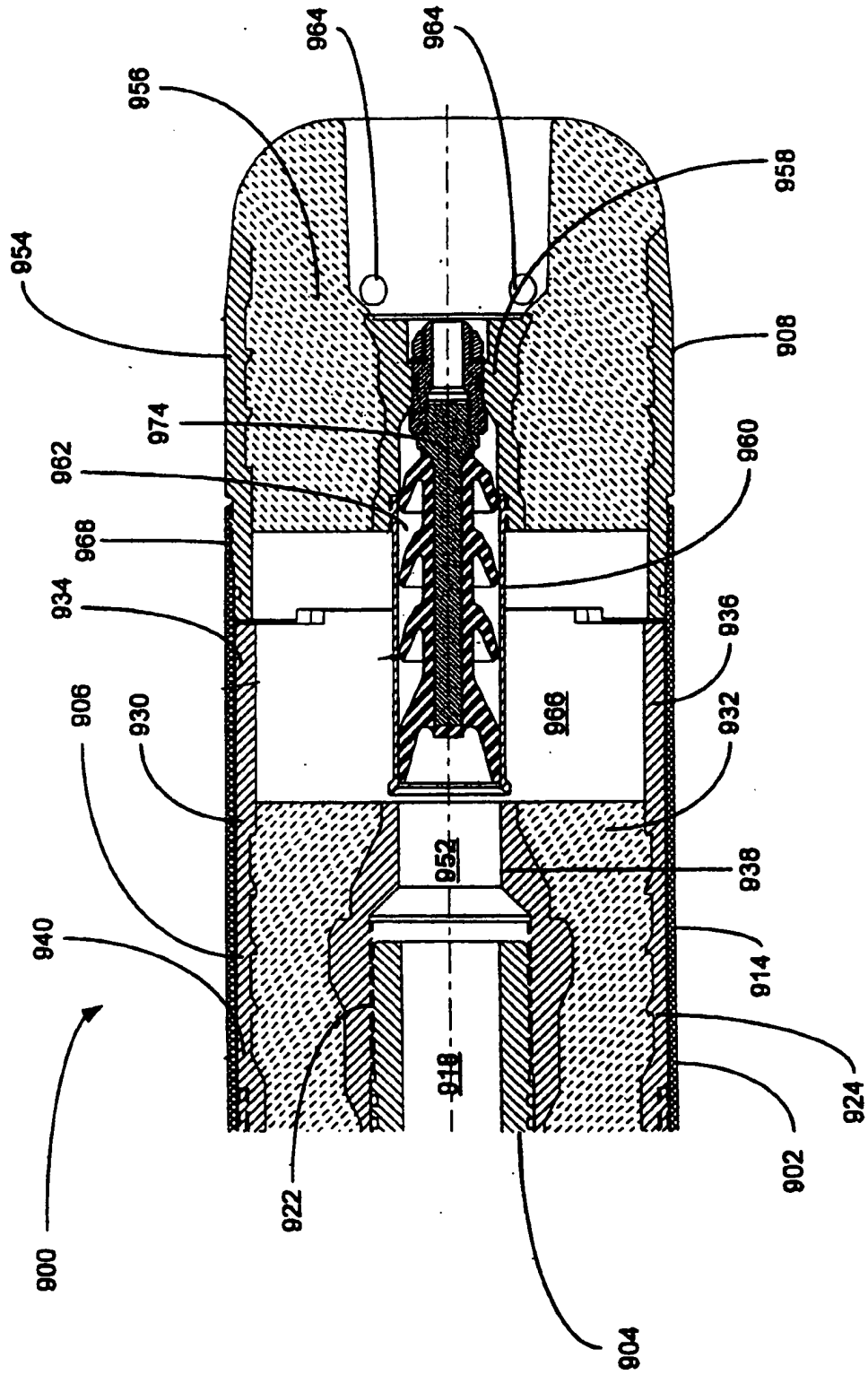

FIGURE 9b

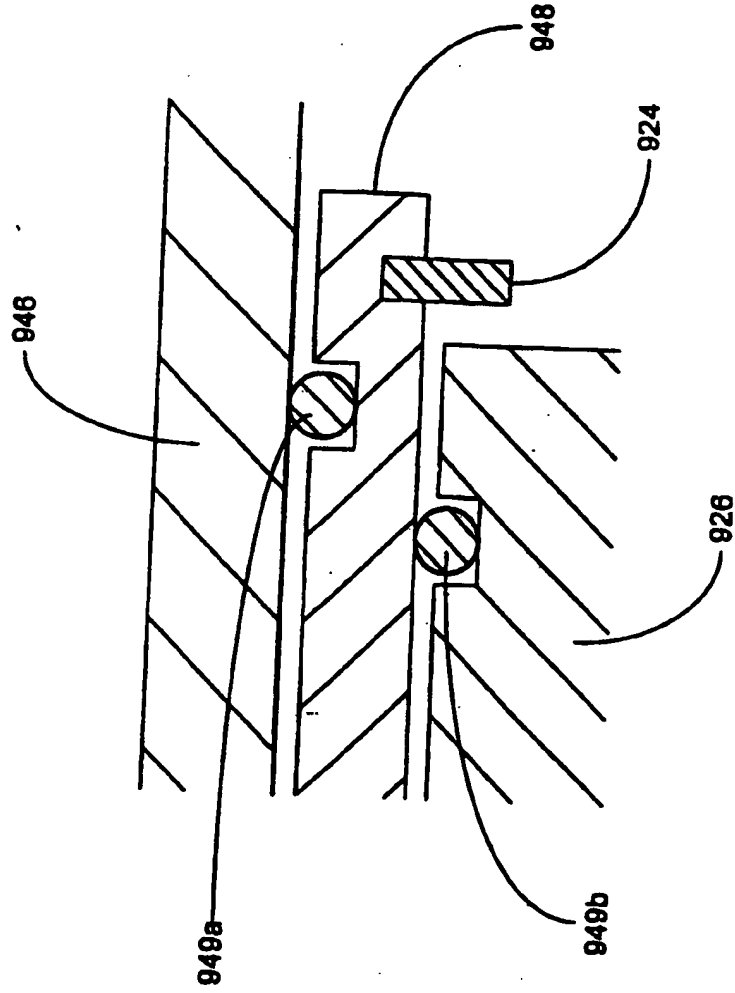

FIGURE 9C

14/26

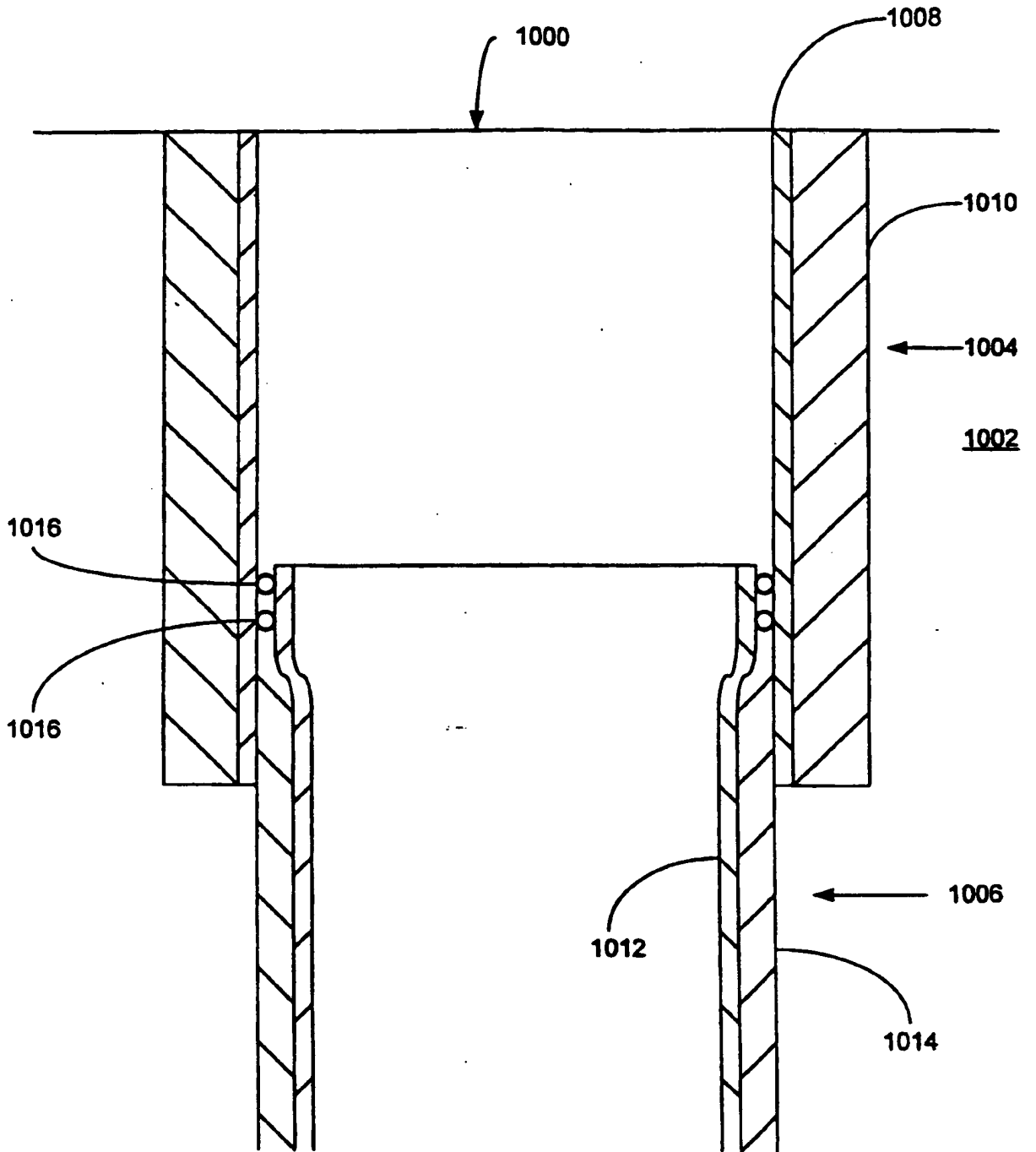

FIGURE 10a

15/26

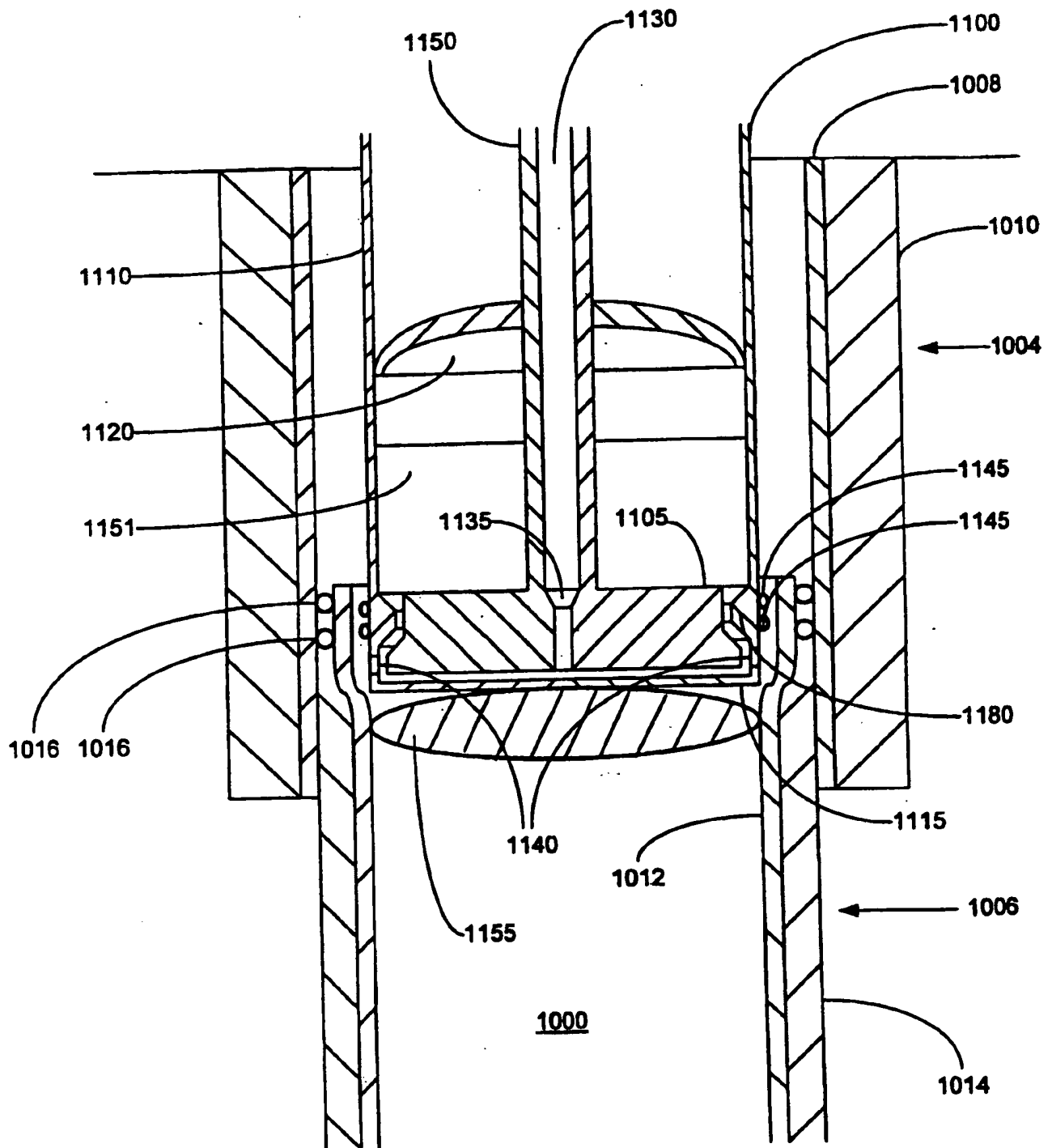

FIGURE 10b

16/26

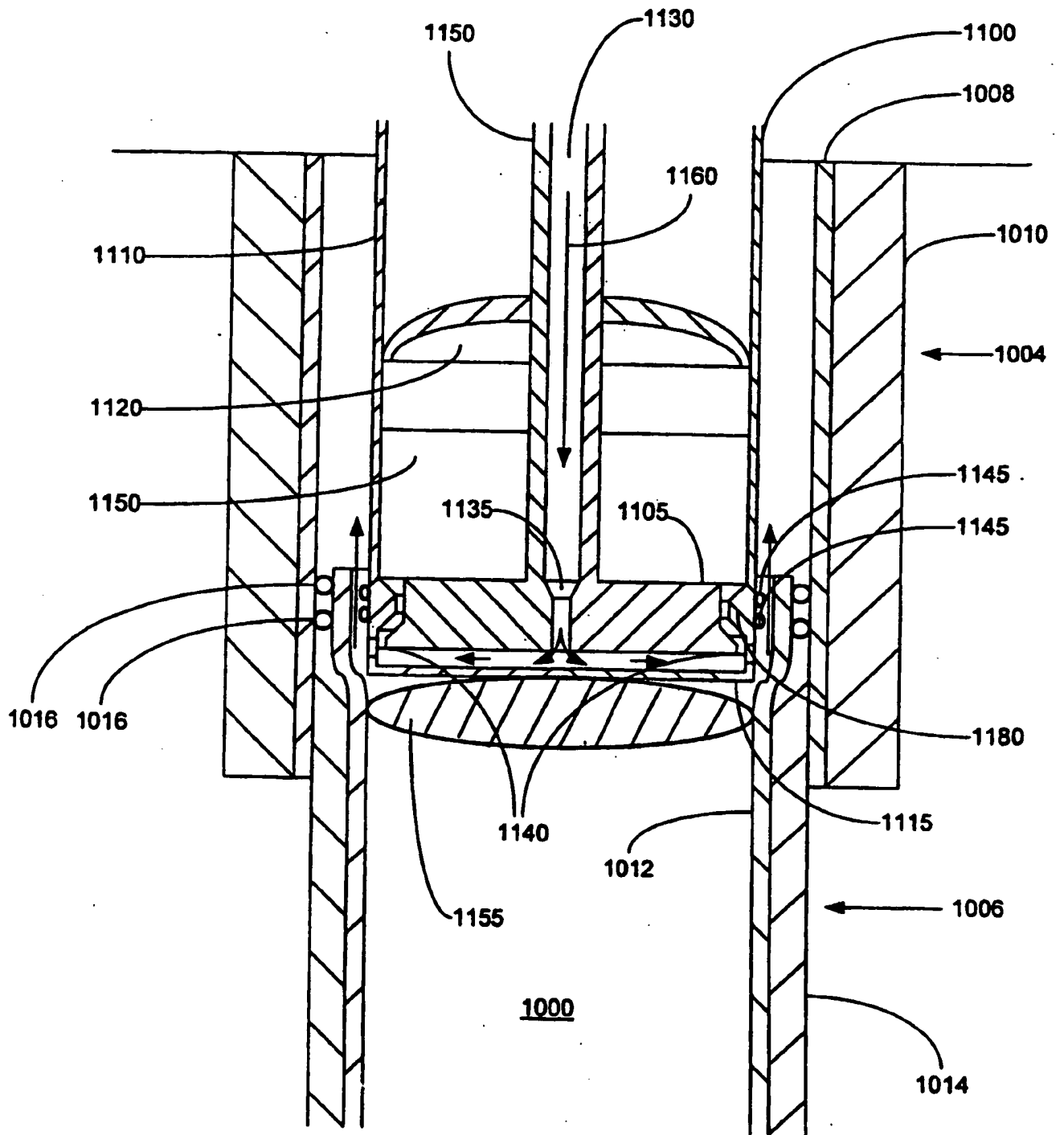

FIGURE 10c

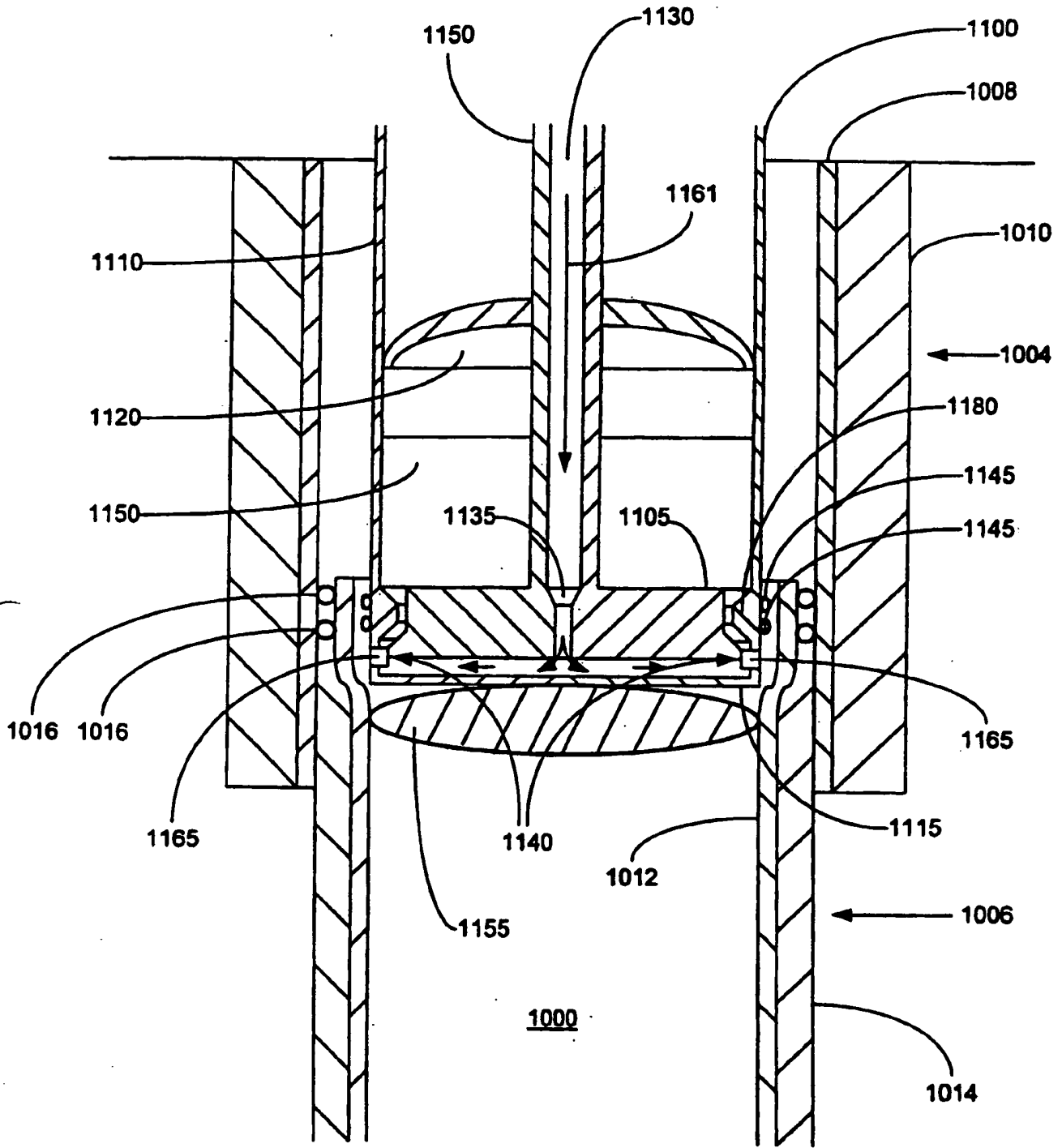

FIGURE 10d

18/26

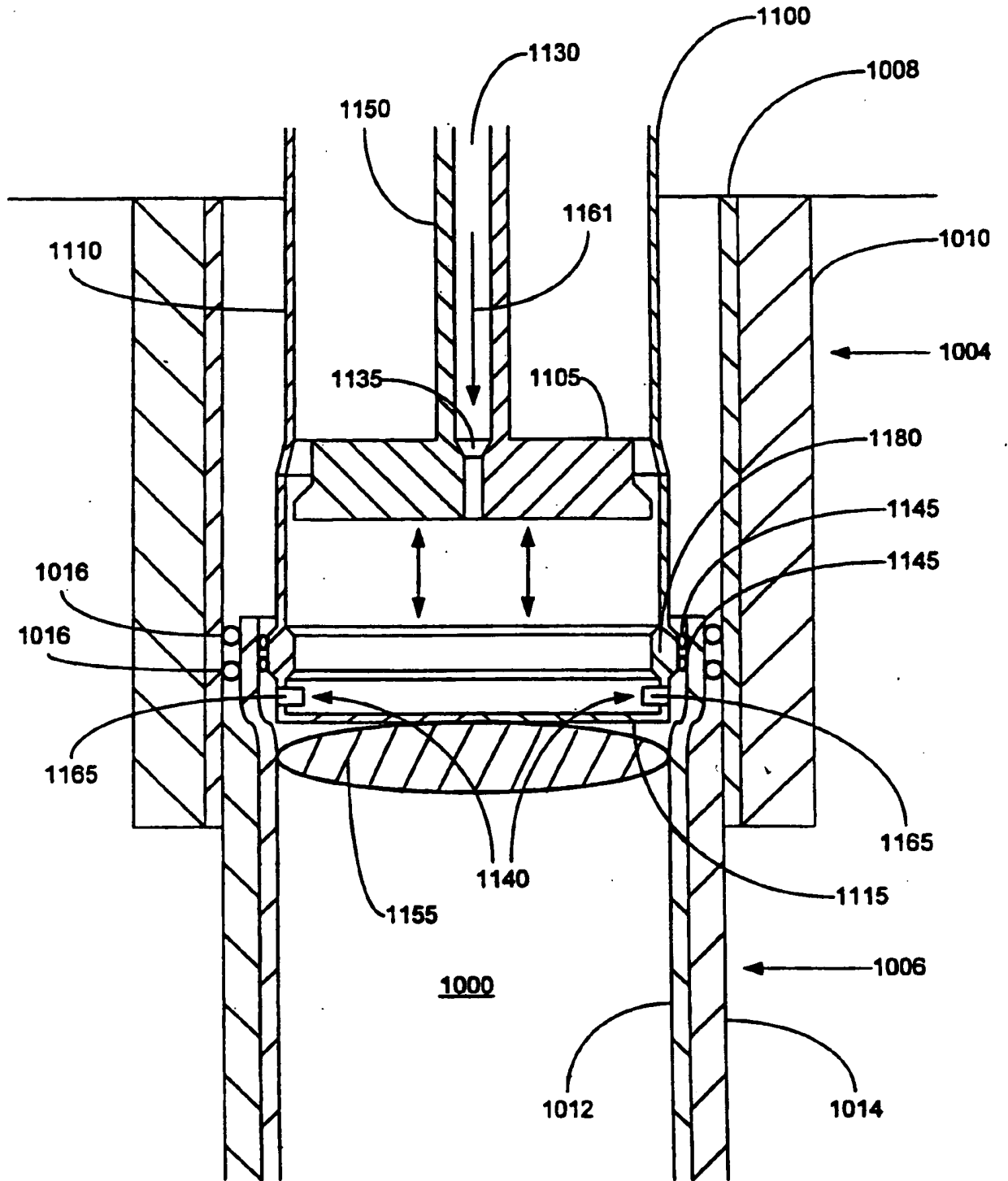

FIGURE 10e

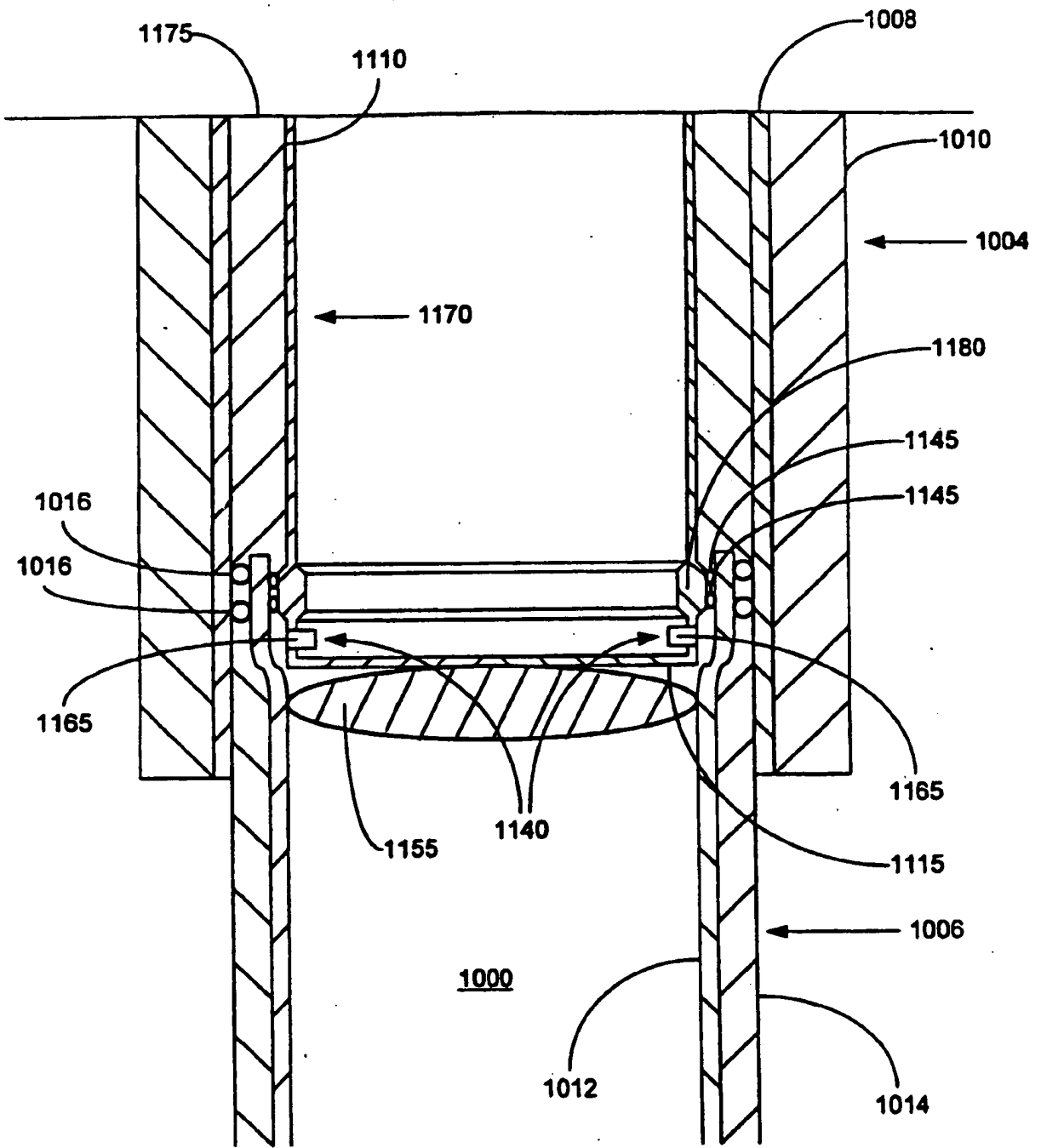

FIGURE 10f

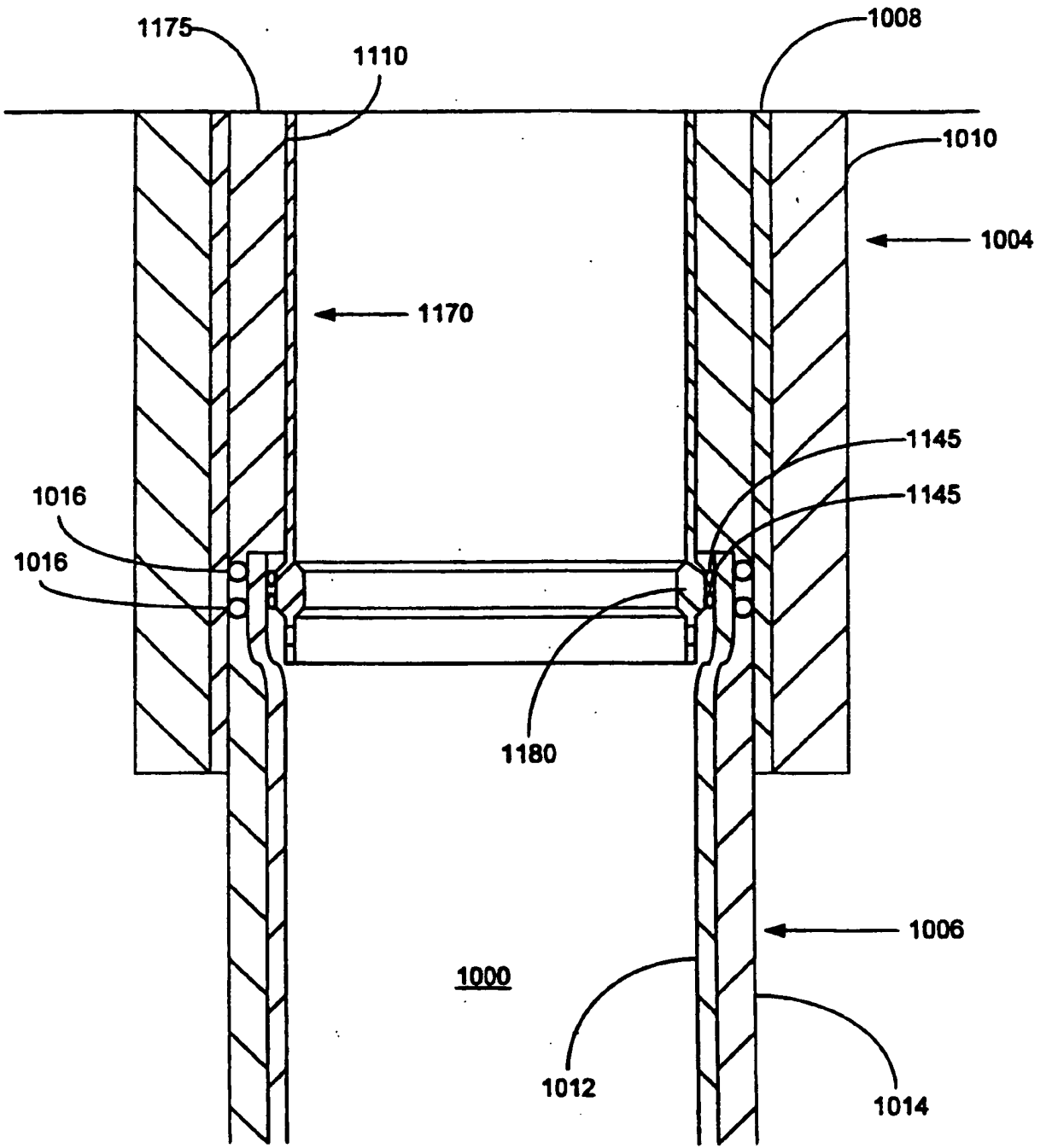

FIGURE 10g

21/26

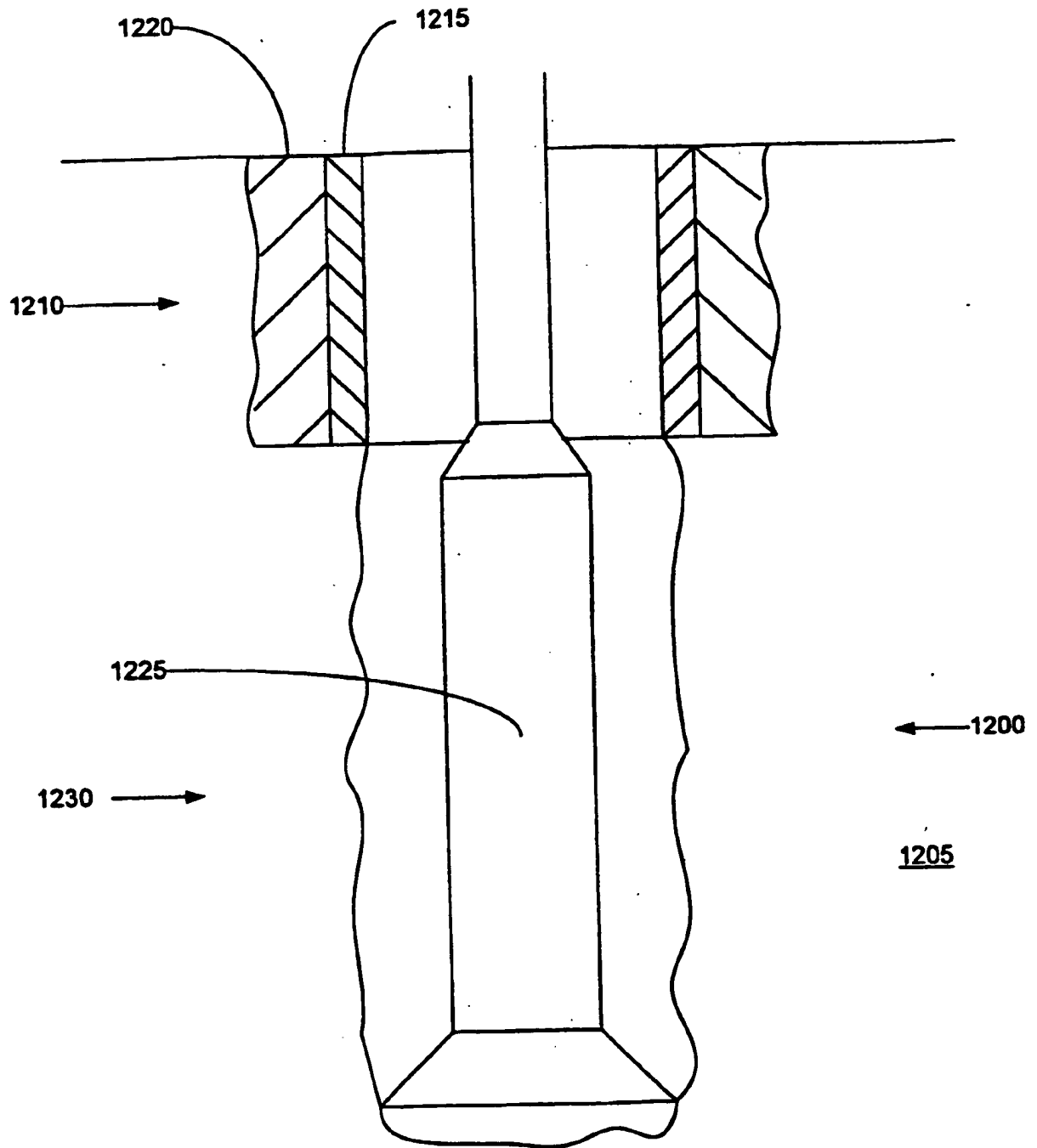

FIGURE 11a

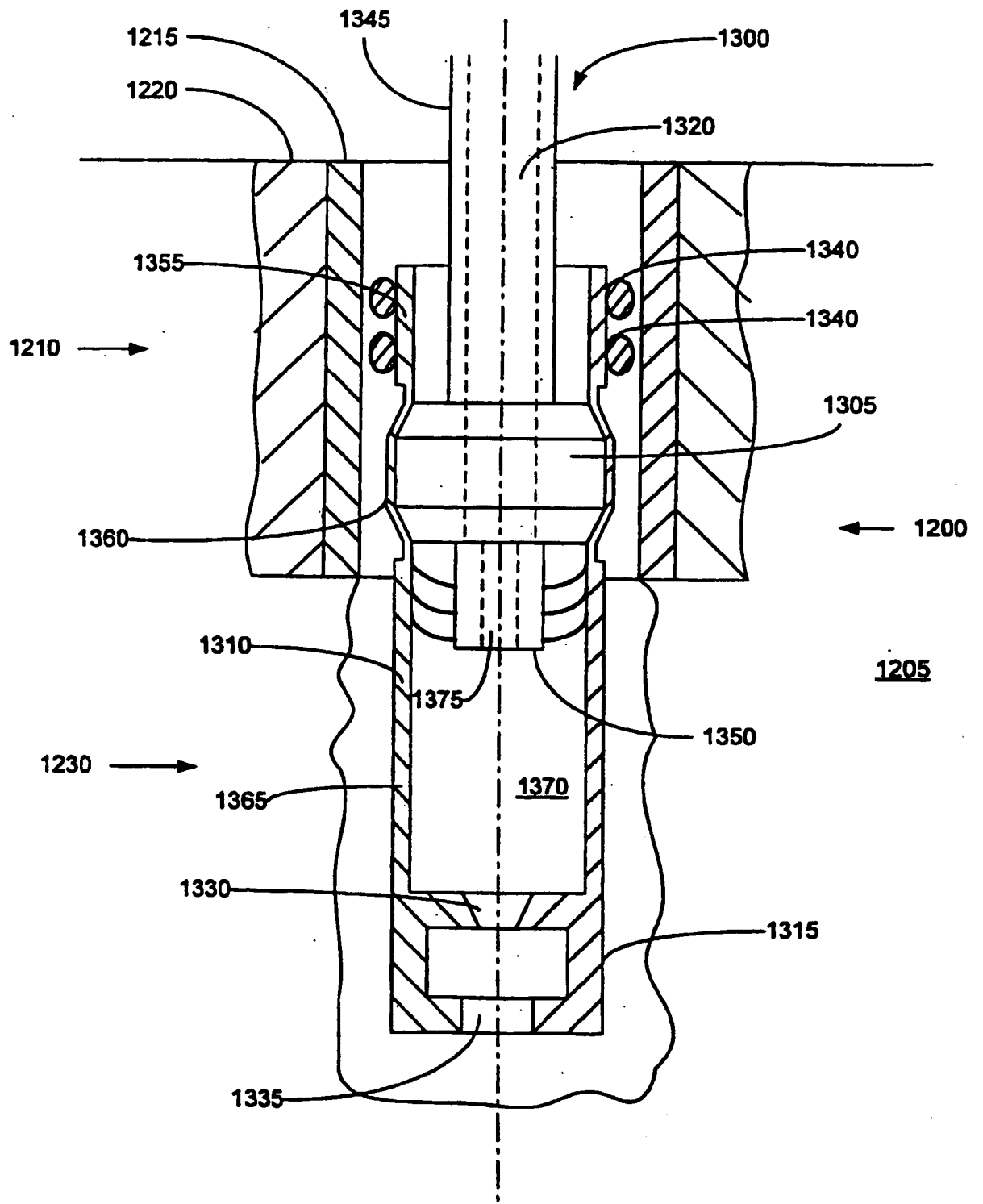

FIGURE 11b

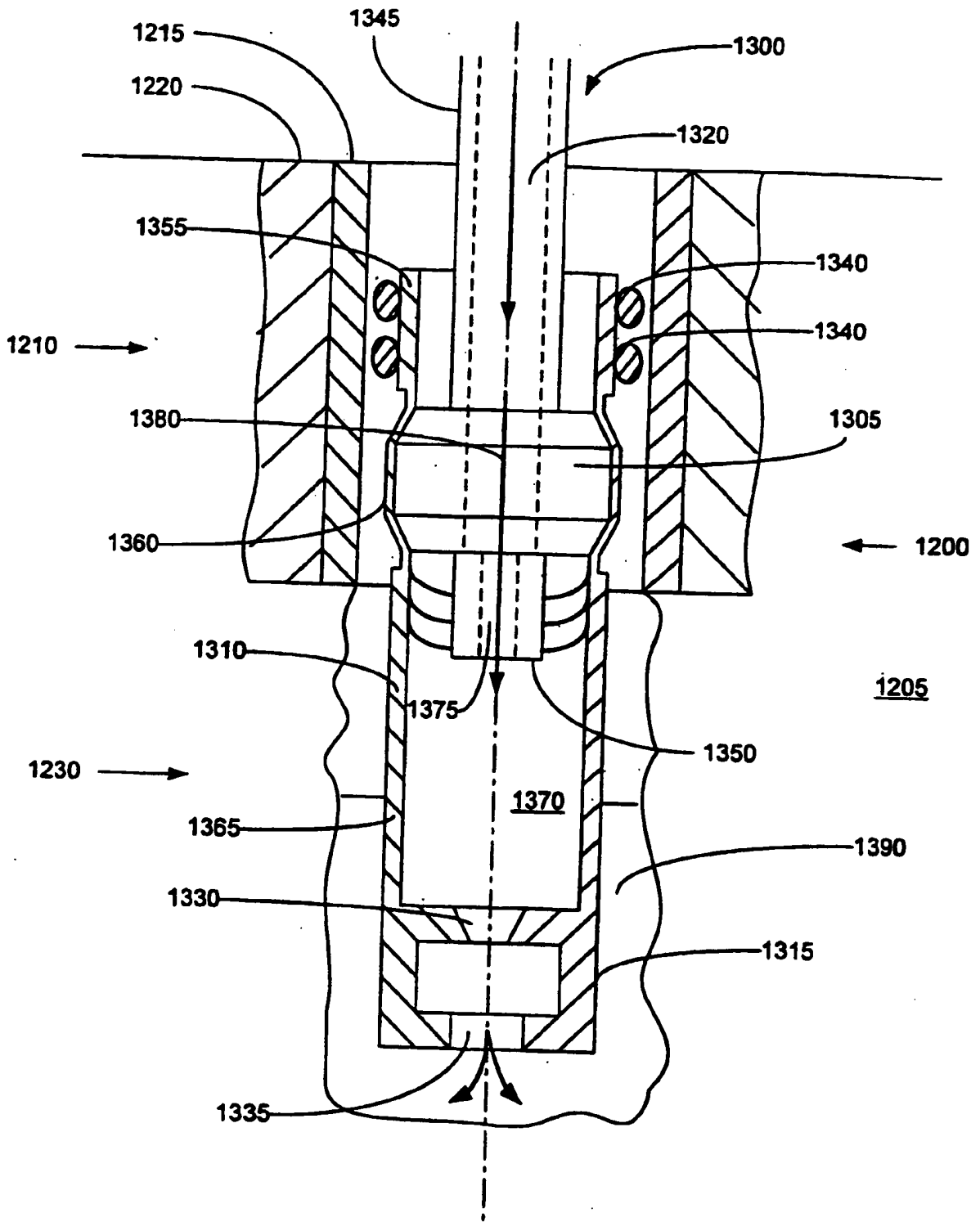

FIGURE 11c

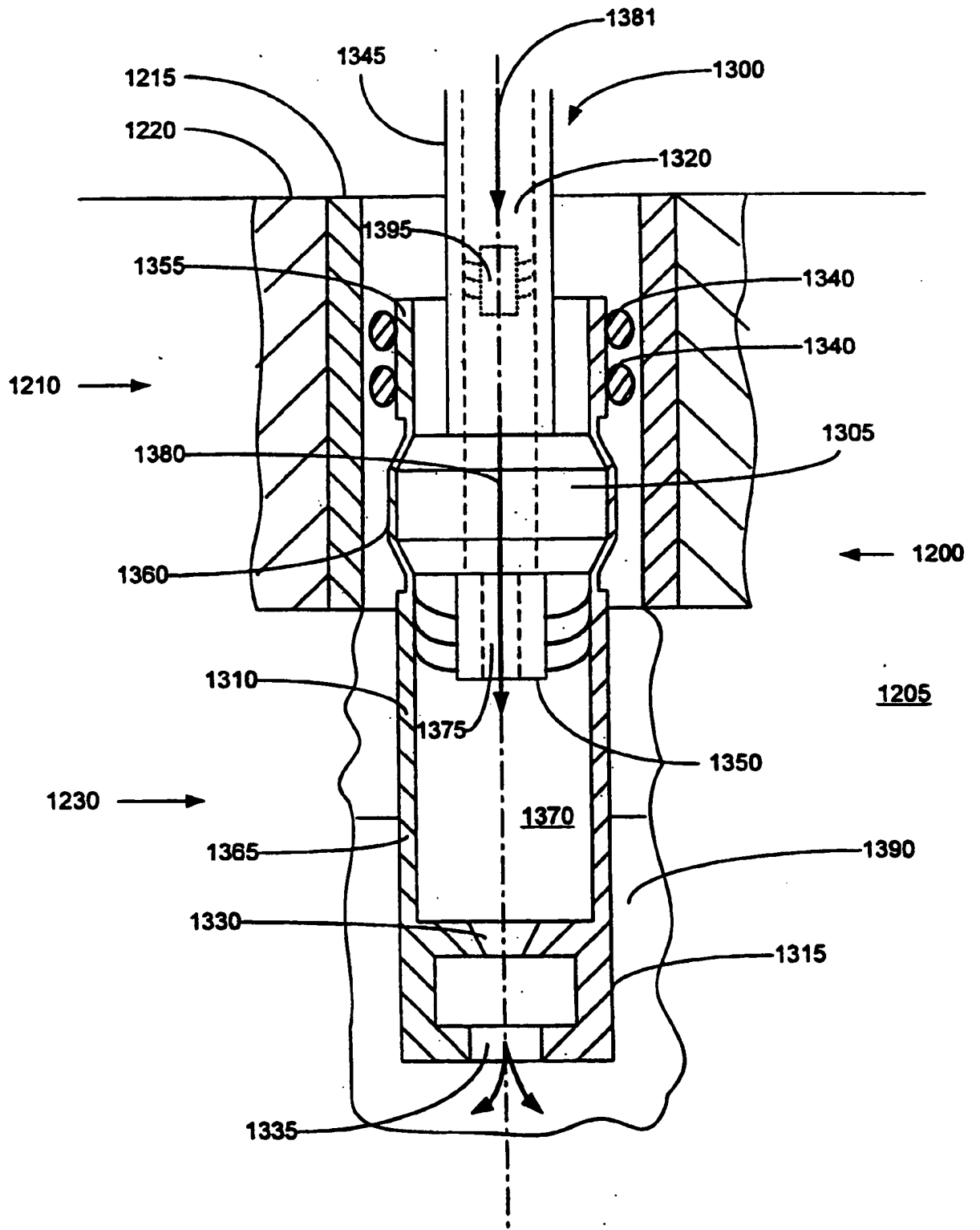

FIGURE 11d

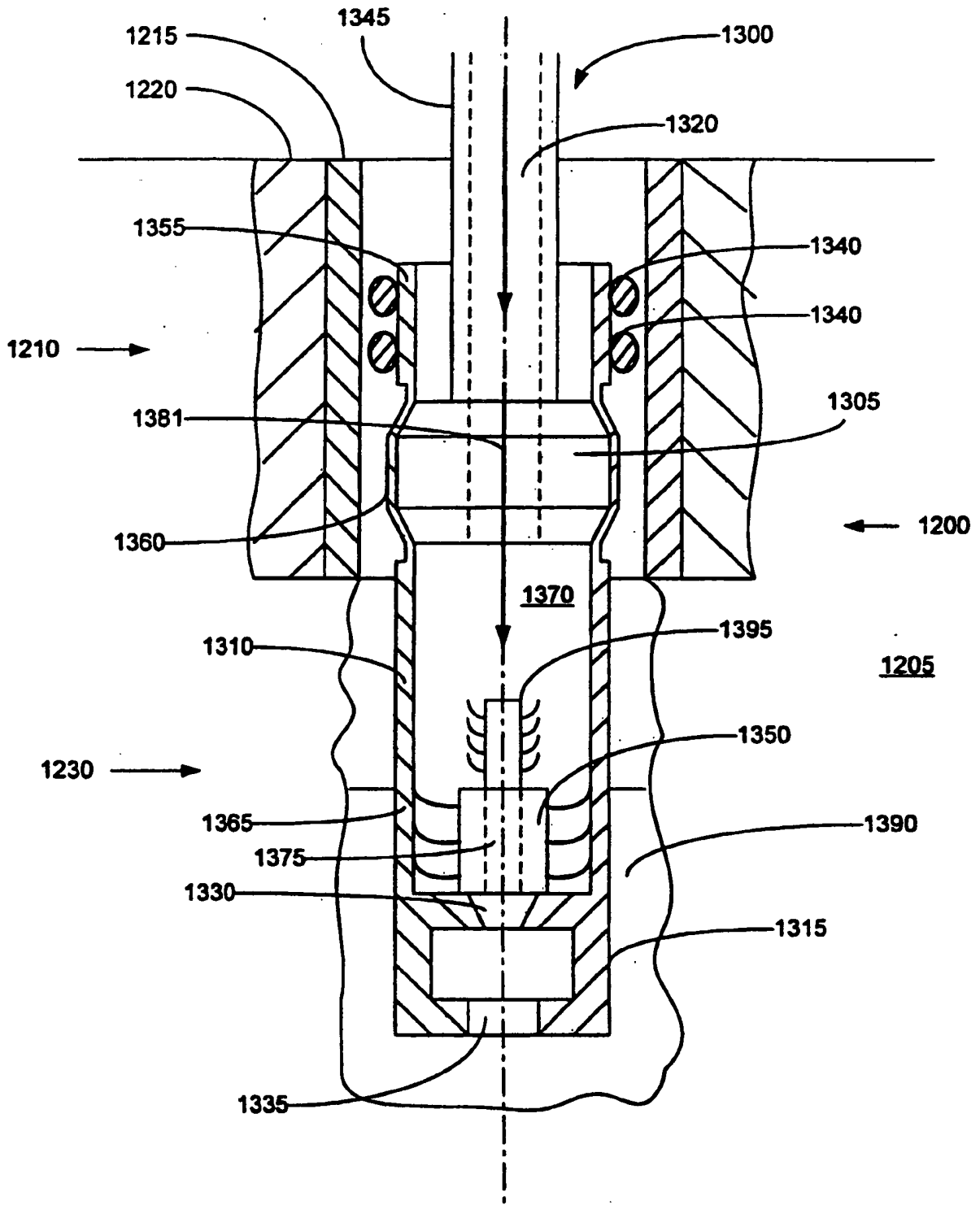

FIGURE 11

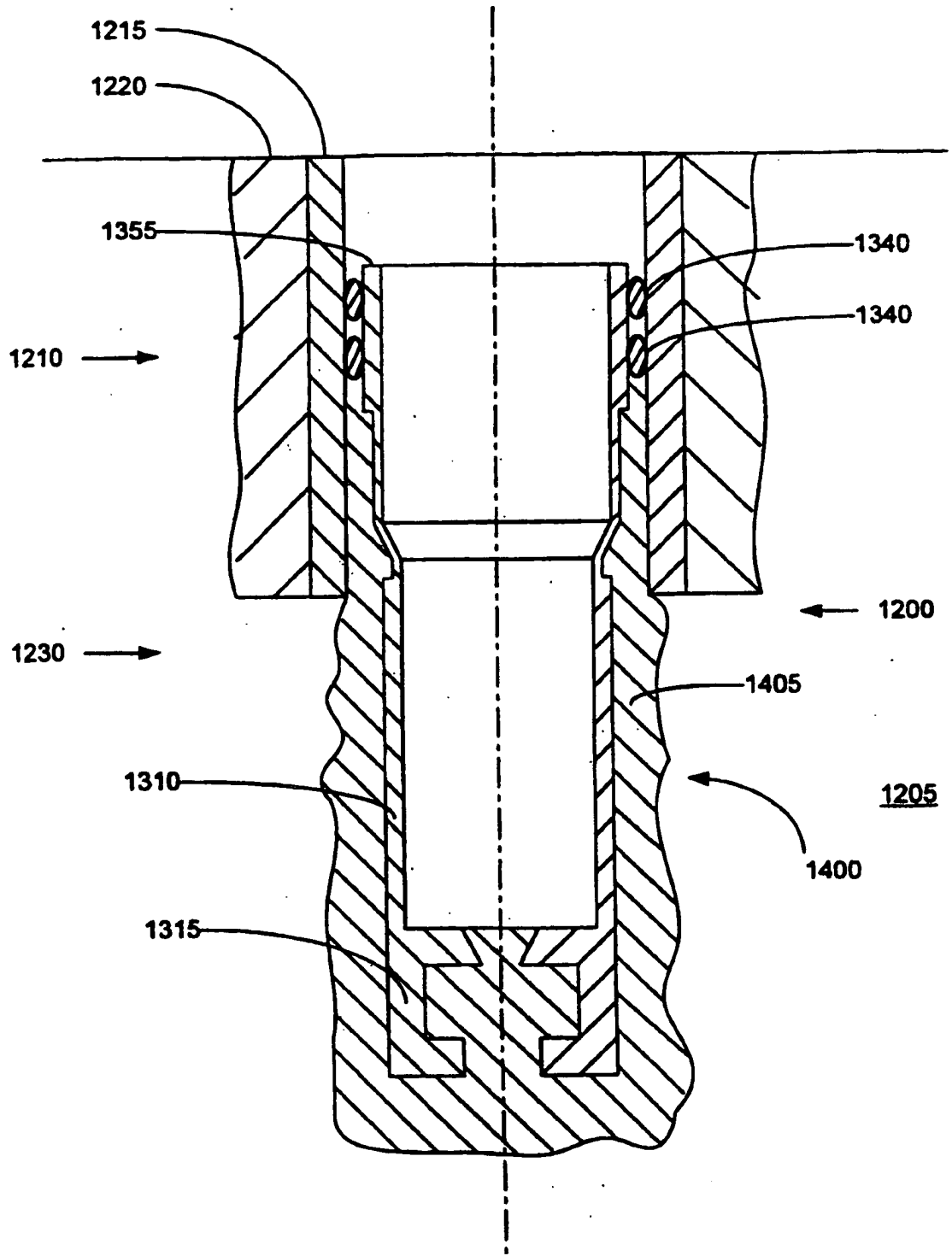
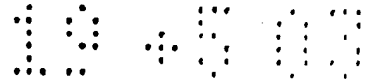

FIGURE 11f



FORMING A WELLBORE CASING BY EXPANSION OF A TUBULAR MEMBER

Background of the Invention

This invention relates generally to wellbore casings, and in particular to wellbore casings that are formed using expandable tubing.

Conventionally, when a wellbore is created, a number of casings are installed in the borehole to prevent collapse of the borehole wall and to prevent undesired outflow of drilling fluid into the formation or inflow of fluid from the formation into the borehole. The borehole is drilled in intervals whereby a casing which is to be installed in a lower borehole interval is lowered through a previously installed casing of an upper borehole interval. As a consequence of this procedure the casing of the lower interval is of smaller diameter than the casing of the upper interval. Thus, the casings are in a nested arrangement with casing diameters decreasing in downward direction. Cement annuli are provided between the outer surfaces of the casings and the borehole wall to seal the casings from the borehole wall. As a consequence of this nested arrangement a relatively large borehole diameter is required at the upper part of the wellbore. Such a large borehole diameter involves increased costs due to heavy casing handling equipment, large drill bits and increased volumes of drilling fluid and drill cuttings. Moreover, increased drilling rig time is involved due to required cement pumping, cement hardening, required equipment changes due to large variations in hole diameters drilled in the course of the well, and the large volume of cuttings drilled and removed.

The present invention is directed to overcoming one or more of the limitations of the existing procedures for forming new sections of casing in a wellbore.

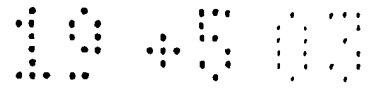

Summary of the Invention

According to one aspect of the present invention, there is provided a method of creating a casing in a borehole located in a subterranean formation, comprising: installing a 5 tubular liner and a mandrel in the borehole; injecting a fluidic material into the borehole; injecting the fluidic material through the mandrel; pressurizing a portion of an interior region of the tubular liner below the mandrel; and 10 radially expanding at least a portion of the tubular liner in the borehole by extruding at least a portion of the tubular liner off of the mandrel.

According to another aspect of the present invention, there is provided a method of creating a casing in a borehole located in a section of a subterranean formation, the borehole 15 having an already existing casing, comprising: drilling out a new section of the borehole adjacent to the already existing casing; placing a tubular liner and an expandable mandrel into the new section of the borehole; overlapping the tubular liner with the already existing casing; injecting a hardenable 20 fluidic sealing material into an annular region between the tubular liner and the new section of the borehole; fluidically isolating the annular region between the tubular liner and the new section of the borehole from an interior region of the tubular liner below the mandrel; injecting a non hardenable 25 fluidic material into the interior region of the tubular liner below the mandrel; extruding the tubular liner off of the expandable mandrel; sealing the overlap between the tubular liner and the already existing casing; supporting the tubular liner with the overlap with the already existing casing; 30 removing the mandrel from the borehole; testing the integrity of the seal of the overlap between the tubular liner and the already existing casing; removing at least a portion of the hardenable fluidic sealing material from the interior of the tubular liner; curing the remaining portions of the hardenable

fluidic sealing material; and removing at least a portion of the cured hardenable fluidic sealing material within the tubular liner.

According to another aspect of the present invention, 5 there is provided an apparatus comprising: a support member, the support member including a first fluid passage; a mandrel coupled to the support member, the mandrel including: a second fluid passage; a tubular member coupled to the mandrel; and a shoe coupled to the 10 tubular member, the shoe including a third fluid passage; wherein the first, second and third fluid passages are operably coupled.

According to another aspect of the present invention, there is provided an apparatus 15 comprising: a support member, the support member including: a first fluid passage; a second fluid passage; and a flow control valve coupled to the first and second fluid passages; an expandable mandrel coupled to the support member, the expandable mandrel including a third fluid passage coupled to 20 the first fluid passage; a tubular member coupled to the mandrel, the tubular member including one or more sealing elements; a shoe coupled to the tubular member, the shoe including: a fourth fluid passage coupled to the third fluid passage, the fourth fluid passage adapted to receive a stop 25 member; and one or more exhaust passages coupled to the fourth fluid passage for injecting fluidic material outside of the shoe; and at least one sealing member coupled to the support member, the sealing member adapted to prevent the entry of foreign material into an interior region of the tubular 30 member.

According to another aspect of the present invention, there is provided a method of joining a second tubular member to a first tubular member, the first tubular member having an inner diameter greater than an outer diameter of the second

tubular member, comprising: positioning a mandrel within an interior region of the second tubular member; pressurizing a portion of the interior region of the second tubular member below the mandrel by injecting a fluidic material into the
5 second tubular member through the mandrel; and extruding the second tubular member off of the mandrel into engagement with the first tubular member.

According to another aspect of the present invention, there is provided an apparatus
10 comprising: a support member including a first fluid passage; a mandrel coupled to the support member, the mandrel including: a second fluid passage operably coupled to the first fluid passage; an interior portion; and an exterior portion; wherein the interior portion of the mandrel is
15 drillable; an expandable tubular member coupled to the mandrel; and a shoe coupled to the tubular member, the shoe including: a third fluid passage operably coupled to the second fluid passage; an interior portion; and an exterior portion; wherein the interior portion of the shoe is
20 drillable.

According to another aspect of the present invention, there is provided an apparatus
comprising: a support member defining a first fluid passage; an expansion mandrel coupled to the support member including
25 an outer expansion surface and defining a second fluid passage; a tubular liner coupled to the expansion mandrel; and a shoe coupled to the tubular liner defining a third fluid passage; wherein the first, second and third fluid passages are operably coupled; and wherein the interface between the
30 tubular liner and the expansion mandrel is not fluid tight.

According to another aspect of the present invention, there is provided an apparatus
comprising: a support member defining a first fluid passage; an expansion mandrel coupled to the support member including

10/10

an outer expansion surface and defining a second fluid passage; a tubular liner coupled to the expansion mandrel; a shoe coupled to the tubular liner defining a third fluid passage; and a packer coupled to the shoe; wherein the first, 5 second and third fluid passages are operably coupled.

According to another aspect of the present invention, there is provided an apparatus comprising: a support member defining a first fluid passage; an expansion mandrel coupled to the support member including 10 an outer expansion surface and defining a second fluid passage; a tubular liner coupled to the expansion mandrel; and a shoe coupled to the tubular liner defining a third fluid passage; wherein the first, second and third fluid passages are operably coupled; and wherein the third fluid passage 15 defined by the shoe comprises one or more radial passages.

According to another aspect of the present invention, there is provided an apparatus comprising: a support member defining a first fluid passage; an expansion mandrel coupled to the support member including 20 an outer expansion surface and defining a second fluid passage; a tubular liner coupled to the expansion mandrel; and a shoe coupled to the tubular liner defining a third fluid passage; wherein the first, second and third fluid passages are operably coupled; and wherein the wall thickness of a 25 portion of the tubular liner above the expansion surface of the expansion mandrel is greater than a wall thickness of a portion of the tubular liner below the expansion surface of the expansion mandrel.

30 **Brief Description of the Drawings**

Fig. 1 is a fragmentary cross-sectional view illustrating the drilling of a new section of a well borehole.

Fig. 1

Fig. 2 is a fragmentary cross-sectional view illustrating the placement of an embodiment of an apparatus for creating a casing within the new section of the well borehole.

Fig. 3 is a fragmentary cross-sectional view illustrating the injection of a first quantity of a hardenable fluidic sealing material into the new section of the well borehole.

Fig. 3a is another fragmentary cross-sectional view illustrating the injection of a first quantity of a hardenable fluidic sealing material into the new section of the well borehole.

Fig. 4 is a fragmentary cross-sectional view illustrating the injection of a second quantity of a hardenable fluidic sealing material into the new section of the well borehole.

Fig. 5 is a fragmentary cross-sectional view illustrating the drilling out of a portion of the cured hardenable fluidic sealing material from the new section of the well borehole.

Fig. 6 is a cross-sectional view of an overlapping joint between adjacent tubular members which can be utilised in apparatus of the present invention.

Fig. 7 is a fragmentary cross-sectional view of a preferred embodiment of the apparatus for creating a casing within a well borehole.

Fig. 8 is a fragmentary cross-sectional illustration of the placement of an expanded tubular member within another tubular member.

Fig. 9 is a cross-sectional illustration of a preferred embodiment of an apparatus for forming a casing including a drillable mandrel and shoe.

Fig. 9a is another cross-sectional illustration of the apparatus of Fig. 9.

Fig. 9b is another cross-sectional illustration of the apparatus of Fig. 9.

Fig. 9c is another cross-sectional illustration of the apparatus of Fig. 9.

FIG. 10a is a cross-sectional illustration of a wellbore including a pair of adjacent overlapping casings.

FIG. 10b is a cross-sectional illustration of an apparatus and method for creating a tie-back liner using an expandible tubular member.

5 FIG. 10c is a cross-sectional illustration of the pumping of a fluidic sealing material into the annular region between the tubular member and the existing casing.

FIG. 10d is a cross-sectional illustration of the pressurizing of the interior of the tubular member below the mandrel.

10 FIG. 10e is a cross-sectional illustration of the extrusion of the tubular member off of the mandrel.

FIG. 10f is a cross-sectional illustration of the tie-back liner before drilling out the shoe and packer.

FIG. 10g is a cross-sectional illustration of the completed tie-back liner
15 created using an expandible tubular member.

FIG. 11a is a fragmentary cross-sectional view illustrating the drilling of a new section of a well borehole.

FIG. 11b is a fragmentary cross-sectional view illustrating the placement of an embodiment of an apparatus for hanging a tubular liner within the new section
20 of the well borehole.

FIG. 11c is a fragmentary cross-sectional view illustrating the injection of a first quantity of a hardenable fluidic sealing material into the new section of the well borehole.

FIG. 11d is a fragmentary cross-sectional view illustrating the introduction
25 of a wiper dart into the new section of the well borehole.

FIG. 11e is a fragmentary cross-sectional view illustrating the injection of a second quantity of a hardenable fluidic sealing material into the new section of the well borehole.

FIG. 11f is a fragmentary cross-sectional view illustrating the completion
30 of the tubular liner.

Detailed Description of the Illustrative Embodiments

An apparatus and method for forming a wellbore casing within a subterranean formation is provided. The apparatus and method permits a wellbore casing to be formed in a subterranean formation by placing a tubular member and a mandrel in a new section of a wellbore, and then extruding the tubular member off of the mandrel by pressurizing an interior portion of the tubular member. The apparatus and method further permits adjacent tubular members in the wellbore to be joined using an overlapping joint that prevents fluid and or gas passage. The apparatus and method further permits a new tubular member to be supported by an existing tubular member by expanding the new tubular member into engagement with the existing tubular member. The apparatus and method further minimizes the reduction in the hole size of the wellbore casing necessitated by the addition of new sections of wellbore casing.

An apparatus and method for forming a tie-back liner using an expandable tubular member is also provided. The apparatus and method permits a tie-back liner to be created by extruding a tubular member off of a mandrel by pressurizing and interior portion of the tubular member. In this manner, a tie-back liner is produced. The apparatus and method further permits adjacent tubular members in the wellbore to be joined using an overlapping joint that prevents fluid and/or gas passage. The apparatus and method further permits a new tubular member to be supported by an existing tubular member by expanding the new tubular member into engagement with the existing tubular member.

An apparatus and method for expanding a tubular member is also provided that includes an expandable tubular member, mandrel and a shoe. In a preferred embodiment, the interior portions of the apparatus is composed of materials that permit the interior portions to be removed using a conventional drilling apparatus. In this manner, in the event of a malfunction in a downhole region, the apparatus may be easily removed.

An apparatus and method for hanging an expandable tubular liner in a wellbore is also provided. The apparatus and method permit a tubular liner to be attached to an existing section of casing. The apparatus and method further have application to the joining of tubular members in general.

Referring initially to Figs. 1-5, an embodiment of an apparatus and method for forming a wellbore casing within a subterranean formation will now be described. As illustrated in Fig. 1, a wellbore 100 is positioned in a subterranean formation 105. The wellbore 100 includes an existing cased section 110 having a tubular casing 115 and an annular outer layer of cement 120.

In order to extend the wellbore 100 into the subterranean formation 105, a drill string 125 is used in a well known manner to drill out material from the subterranean formation 105 to form a new section 130.

As illustrated in Fig. 2, an apparatus 200 for forming a wellbore casing in a subterranean formation is then positioned in the new section 130 of the wellbore 100. The apparatus 200 preferably includes an expandable mandrel or pig 205, a tubular member 210, a shoe 215, a lower cup seal 220, an upper cup seal 225, a fluid passage 230, a fluid passage 235, a fluid passage 240, seals 245, and a support member 250.

The expandable mandrel 205 is coupled to and supported by the support member 250. The expandable mandrel 205 is preferably adapted to controllably expand in a radial direction. The expandable mandrel 205 may comprise any number of conventional commercially available expandable mandrels modified in accordance with the teachings of the present disclosure. In a preferred embodiment, the expandable mandrel 205 comprises a hydraulic expansion tool as disclosed in U.S. Patent No. 5,348,095, the contents of which are incorporated herein by reference, modified in accordance with the teachings of the present disclosure.

The tubular member 210 is supported by the expandable mandrel 205. The tubular member 210 is expanded in the radial direction and extruded off of the expandable mandrel 205. The tubular member 210 may be fabricated from any number of conventional commercially available materials such as, for example, Oilfield Country Tubular Goods (OCTG), 13 chromium steel tubing/casing, or plastic tubing/casing. In a preferred embodiment, the tubular member 210 is fabricated from OCTG in order to maximize strength after expansion. The inner and outer diameters of the tubular member 210 may range, for example, from approximately 1.905 to 119.38 cms (0.75 to 47 inches) and 2.667 to 121.92 cms (1.05 to 48 inches), respectively. In a preferred

(embodiment, the inner and outer diameters of the tubular member 210 range from about 7.62 to 39.37 cms (3 to 15.5 inches) and 8.89 to 40.64 cms (3.5 to 16 inches), respectively in order to optimally provide minimal telescoping effect in the most commonly drilled wellbore sizes. The tubular member 210 preferably comprises a solid member.

In a preferred embodiment, the end portion 260 of the tubular member 210 is slotted, perforated, or otherwise modified to catch or slow down the mandrel 205 when it completes the extrusion of tubular member 210. In a preferred embodiment, the length of the tubular member 210 is limited to minimize the possibility of buckling. For typical tubular member 210 materials, the length of the tubular member 210 is preferably limited to between about 12.192 to 6096m (40 to 20,000 feet) in length.

The shoe 215 is coupled to the expandable mandrel 205 and the tubular member 210. The shoe 215 includes fluid passage 240. The shoe 215 may comprise any number of conventional commercially available shoes such as, for example, Super Seal II float shoe, Super Seal II Down-Jet float shoe or a guide shoe with a sealing sleeve for a latch down plug modified in accordance with the teachings of the present disclosure. In a preferred embodiment, the shoe 215 comprises an aluminum down-jet guide shoe with a sealing sleeve for a latch-down plug available from Halliburton Energy Services in Dallas, TX, modified in accordance with the teachings of the present disclosure, in order to optimally guide the tubular member 210 in the wellbore, optimally provide an adequate seal between the interior and exterior diameters of the overlapping joint between the tubular members, and to optimally allow the complete drill out of the shoe and plug after the completion of the cementing and expansion operations.

In a preferred embodiment, the shoe 215 includes one or more through and side outlet ports in fluidic communication with the fluid passage 240. In this manner, the shoe 215 optimally injects hardenable fluidic sealing material into the region outside the shoe 215 and tubular member 210. In a preferred embodiment, the shoe 215 includes the fluid passage 240 having an inlet geometry that can receive a dart and/or a ball sealing member. In this manner, the fluid passage 240 can be optimally sealed off by introducing a plug, dart and/or ball sealing elements into the fluid passage 230.

The lower cup seal 220 is coupled to and supported by the support member 250. The lower cup seal 220 prevents foreign materials from entering the interior region of the tubular member 210 adjacent to the expandable mandrel 205. The lower cup seal 220 may comprise any number of conventional commercially available cup seals such as, for example, TP cups, or Selective Injection Packer (SIP) cups modified in accordance with the teachings of the present disclosure. In a preferred embodiment, the lower cup seal 220 comprises a SIP cup seal, available from Halliburton Energy Services in Dallas, TX in order to optimally block foreign material and contain a body of lubricant.

10 The upper cup seal 225 is coupled to and supported by the support member 250. The upper cup seal 225 prevents foreign materials from entering the interior region of the tubular member 210. The upper cup seal 225 may comprise any number of conventional commercially available cup seals such as, for example, TP cups or SIP cups modified in accordance with the teachings of the present
15 disclosure. In a preferred embodiment, the upper cup seal 225 comprises a SIP cup, available from Halliburton Energy Services in Dallas, TX in order to optimally block the entry of foreign materials and contain a body of lubricant.

The fluid passage 230 permits fluidic materials to be transported to and from the interior region of the tubular member 210 below the expandable mandrel
20 205. The fluid passage 230 is coupled to and positioned within the support member 250 and the expandable mandrel 205. The fluid passage 230 preferably extends from a position adjacent to the surface to the bottom of the expandable mandrel 205. The fluid passage 230 is preferably positioned along a centerline of the apparatus 200.

25 The fluid passage 230 is preferably selected, in the casing running mode of operation, to transport materials such as drilling mud or formation fluids at flow rates and pressures ranging from about 0 to 11356.2355 litres/minute (0 to 3,000 gallons/minute) and 0 to 620.52813 bar (0 to 9,000 psi) in order to minimize drag on the tubular member being run and to minimize surge pressures exerted on the wellbore which could cause a loss of wellbore fluids and lead to hole
30 collapse.

The fluid passage 235 permits fluidic materials to be released from the fluid passage 230. In this manner, during placement of the apparatus 200 within the

new section 130 of the wellbore 100, fluidic materials 255 forced up the fluid passage 230 can be released into the wellbore 100 above the tubular member 210 thereby minimizing surge pressures on the wellbore section 130. The fluid passage 235 is coupled to and positioned within the support member 250. The fluid
5 passage is further fluidically coupled to the fluid passage 230.

The fluid passage 235 preferably includes a control valve for controllably opening and closing the fluid passage 235. In a preferred embodiment, the control valve is pressure activated in order to controllably minimize surge pressures. The fluid passage 235 is preferably positioned substantially orthogonal to the centerline
10 of the apparatus 200.

The fluid passage 235 is preferably selected to convey fluidic materials at flow rates and pressures ranging from about 0 to 11356.2355 litres/minute (0 to 3,000 gallons/minute) and 0 to 620.52813 bar (0 to 9,000 psi) in order to reduce the drag on the apparatus 200 during insertion into the new section 130 of the wellbore 100 and to
15 minimize surge pressures on the new wellbore section 130.

The fluid passage 240 permits fluidic materials to be transported to and from the region exterior to the tubular member 210 and shoe 215. The fluid passage 240 is coupled to and positioned within the shoe 215 in fluidic communication with the interior region of the tubular member 210 below the
20 expandable mandrel 205. The fluid passage 240 preferably has a cross-sectional shape that permits a plug, or other similar device, to be placed in fluid passage 240 to thereby block further passage of fluidic materials. In this manner, the interior region of the tubular member 210 below the expandable mandrel 205 can be fluidically isolated from the region exterior to the tubular member 210. This permits
25 the interior region of the tubular member 210 below the expandable mandrel 205 to be pressurized. The fluid passage 240 is preferably positioned substantially along the centerline of the apparatus 200.

The fluid passage 240 is preferably selected to convey materials such as cement, drilling mud or epoxies at flow rates and pressures ranging from about 0 to
30 11356.2355 litres/minute (0 to 3,000 gallons/minute) and 0 to 620.52813 bar (0 to 9,000 psi) in order to optimally fill the annular region between the tubular member 210 and the new section 130 of the wellbore 100 with fluidic materials. In a preferred embodiment, the fluid passage 240

includes an inlet geometry that can receive a dart and/or a ball sealing member. In this manner, the fluid passage 240 can be sealed off by introducing a plug, dart and/or ball sealing elements into the fluid passage 230.

The seals 245 are coupled to and supported by an end portion 260 of the tubular member 210. The seals 245 are further positioned on an outer surface 265 of the end portion 260 of the tubular member 210. The seals 245 permit the overlapping joint between the end portion 270 of the casing 115 and the portion 260 of the tubular member 210 to be fluidically sealed. The seals 245 may comprise any number of conventional commercially available seals such as, for example, lead, rubber, Teflon™, or epoxy seals modified in accordance with the teachings of the present disclosure. In a preferred embodiment, the seals 245 are molded from Stratalock epoxy available from Halliburton Energy Services in Dallas, TX in order to optimally provide a load bearing interference fit between the end 260 of the tubular member 210 and the end 270 of the existing casing 115.

In a preferred embodiment, the seals 245 are selected to optimally provide a sufficient frictional force to support the expanded tubular member 210 from the existing casing 115. In a preferred embodiment, the frictional force optimally provided by the seals 245 ranges from about 68,947.57 to 68,947.57 bar (1,000 to 1,000,000 lbf) in order to optimally support the expanded tubular member 210.

The support member 250 is coupled to the expandable mandrel 205, tubular member 210, shoe 215, and seals 220 and 225. The support member 250 preferably comprises an annular member having sufficient strength to carry the apparatus 200 into the new section 130 of the wellbore 100. In a preferred embodiment, the support member 250 further includes one or more conventional centralizers (not illustrated) to help stabilize the apparatus 200.

In a preferred embodiment, a quantity of lubricant 275 is provided in the annular region above the expandable mandrel 205 within the interior of the tubular member 210. In this manner, the extrusion of the tubular member 210 off of the expandable mandrel 205 is facilitated. The lubricant 275 may comprise any number of conventional commercially available lubricants such as, for example, Lubriplate™, chlorine based lubricants, oil based lubricants or Climax 1500 Antisieze (3100). In a preferred embodiment, the lubricant 275 comprises Climax 1500

Antisieze (3100) available from Climax Lubricants and Equipment Co. in Houston, TX in order to optimally provide optimum lubrication to facilitate the expansion process.

In a preferred embodiment, the support member 250 is thoroughly cleaned 5 prior to assembly to the remaining portions of the apparatus 200. In this manner, the introduction of foreign material into the apparatus 200 is minimized. This minimizes the possibility of foreign material clogging the various flow passages and valves of the apparatus 200.

In a preferred embodiment, before or after positioning the apparatus 200 10 within the new section 130 of the wellbore 100, a couple of wellbore volumes are circulated in order to ensure that no foreign materials are located within the wellbore 100 that might clog up the various flow passages and valves of the apparatus 200 and to ensure that no foreign material interferes with the expansion process.

15 As illustrated in Fig. 3, the fluid passage 235 is then closed and a hardenable fluidic sealing material 305 is then pumped from a surface location into the fluid passage 230. The material 305 then passes from the fluid passage 230 into the interior region 310 of the tubular member 210 below the expandable mandrel 205. The material 305 then passes from the interior region 310 into the fluid passage 20 240. The material 305 then exits the apparatus 200 and fills the annular region 315 between the exterior of the tubular member 210 and the interior wall of the new section 130 of the wellbore 100. Continued pumping of the material 305 causes the material 305 to fill up at least a portion of the annular region 315.

The material 305 is preferably pumped into the annular region 315 at pressures 25 and flow rates ranging, for example, from about 0 to 344.73785 bar (0 to 5000 psi) and 0 to 5,678.1177 litres/minute (0 to 1,500 gallons/min), respectively. The optimum flow rate and operating pressures vary as a function of the casing and wellbore sizes, wellbore section length, available pumping equipment, and fluid properties of the fluidic material being pumped. The optimum flow rate and operating pressure are preferably determined using conventional empirical methods.

30 The hardenable fluidic sealing material 305 may comprise any number of conventional commercially available hardenable fluidic sealing materials such as,

for example, slag mix, cement or epoxy. In a preferred embodiment, the hardenable fluidic sealing material 305 comprises a blended cement prepared specifically for the particular well section being drilled from Halliburton Energy Services in Dallas, TX in order to provide optimal support for tubular member 210 while also maintaining optimum flow characteristics so as to minimize difficulties during the displacement of cement in the annular region 315. The optimum blend of the blended cement is preferably determined using conventional empirical methods.

The annular region 315 preferably is filled with the material 305 in sufficient quantities to ensure that, upon radial expansion of the tubular member 210, the annular region 315 of the new section 130 of the wellbore 100 will be filled with material 305.

In a particularly preferred embodiment, as illustrated in Fig. 3a, the wall thickness and/or the outer diameter of the tubular member 210 is reduced in the region adjacent to the mandrel 205 in order optimally permit placement of the apparatus 200 in positions in the wellbore with tight clearances. Furthermore, in this manner, the initiation of the radial expansion of the tubular member 210 during the extrusion process is optimally facilitated.

As illustrated in Fig. 4, once the annular region 315 has been adequately filled with material 305, a plug 405, or other similar device, is introduced into the fluid passage 240 thereby fluidically isolating the interior region 310 from the annular region 315. In a preferred embodiment, a non-hardenable fluidic material 306 is then pumped into the interior region 310 causing the interior region to pressurize. In this manner, the interior of the expanded tubular member 210 will not contain significant amounts of cured material 305. This reduces and simplifies the cost of the entire process. Alternatively, the material 305 may be used during this phase of the process.

Once the interior region 310 becomes sufficiently pressurized, the tubular member 210 is extruded off of the expandable mandrel 205. During the extrusion process, the expandable mandrel 205 may be raised out of the expanded portion of the tubular member 210. In a preferred embodiment, during the extrusion process, the mandrel 205 is raised at approximately the same rate as the tubular

member 210 is expanded in order to keep the tubular member 210 stationary relative to the new wellbore section 130. In an alternative preferred embodiment, the extrusion process is commenced with the tubular member 210 positioned above the bottom of the new wellbore section 130, keeping the mandrel 205 stationary, 5 and allowing the tubular member 210 to extrude off of the mandrel 205 and fall down the new wellbore section 130 under the force of gravity.

The plug 405 is preferably placed into the fluid passage 240 by introducing the plug 405 into the fluid passage 230 at a surface location in a conventional manner. The plug 405 preferably acts to fluidically isolate the hardenable fluidic 10 sealing material 305 from the non hardenable fluidic material 306.

The plug 405 may comprise any number of conventional commercially available devices from plugging a fluid passage such as, for example, Multiple Stage Cementer (MSC) latch-down plug, Omega latch-down plug or three-wiper latch-down plug modified in accordance with the teachings of the present disclosure. In 15 a preferred embodiment, the plug 405 comprises a MSC latch-down plug available from Halliburton Energy Services in Dallas, TX.

After placement of the plug 405 in the fluid passage 240, a non hardenable fluidic material 306 is preferably pumped into the interior region 310 at pressures and flow rates ranging, for example, from approximately 27.579028 to 689.4757 bar (400 20 to 10,000 psi) and 113.5623 to 15141.6473 litres/minute (30 to 4,000 gallons/min). In this manner, the amount of hardenable fluidic sealing material within the interior 310 of the tubular member 210 is minimized. In a preferred embodiment, after placement of the plug 405 in the fluid passage 240, the non hardenable material 306 is preferably pumped into the interior region 310 at pressures and flow rates ranging from approximately 34.473 to 620.52813 bar (500 to 9,000 psi) and 151.4164 to 11356.2355 litres/minute (40 25 to 3,000 gallons/min) in order to maximize the extrusion speed.

In a preferred embodiment, the apparatus 200 is adapted to minimize tensile, burst, and friction effects upon the tubular member 210 during the expansion process. These effects will be depend upon the geometry of the expansion mandrel 205, the material composition of the tubular member 210 and 30 expansion mandrel 205, the inner diameter of the tubular member 210, the wall thickness of the tubular member 210, the type of lubricant, and the yield strength of the tubular member 210. In general, the thicker the wall thickness, the smaller

the inner diameter, and the greater the yield strength of the tubular member 210, then the greater the operating pressures required to extrude the tubular member 210 off of the mandrel 205.

For typical tubular members 210, the extrusion of the tubular member 210 off of the expandable mandrel will begin when the pressure of the interior region 310 reaches, for example, approximately 34.472 to 620.528 bar (500 to 9,000 psi).

During the extrusion process, the expandable mandrel 205 may be raised out of the expanded portion of the tubular member 210 at rates ranging, for example, from about 0 to 5 ft/sec. In a preferred embodiment, during the extrusion process, the expandable mandrel 205 is raised out of the expanded portion of the tubular member 210 at rates ranging from about 0 to 0.6096 m/s (0 to 2 ft/sec) in order to minimize the time required for the expansion process while also permitting easy control of the expansion process.

When the end portion 260 of the tubular member 210 is extruded off of the expandable mandrel 205, the outer surface 265 of the end portion 260 of the tubular member 210 will preferably contact the interior surface 410 of the end portion 270 of the casing 115 to form an fluid tight overlapping joint. The contact pressure of the overlapping joint may range, for example, from approximately 3.447379 to 1,278.9514 bar (50 to 20,000 psi). In a preferred embodiment, the contact pressure of the overlapping joint ranges from approximately 27.579028 to 689.4757 bar (400 to 10,000 psi) in order to provide optimum pressure to activate the annular sealing members 245 and optimally provide resistance to axial motion to accommodate typical tensile and compressive loads.

The overlapping joint between the section 410 of the existing casing 115 and the section 265 of the expanded tubular member 210 preferably provides a gaseous and fluidic seal. In a particularly preferred embodiment, the sealing members 245 optimally provide a fluidic and gaseous seal in the overlapping joint.

In a preferred embodiment, the operating pressure and flow rate of the non hardenable fluidic material 306 is controllably ramped down when the expandable mandrel 205 reaches the end portion 260 of the tubular member 210. In this manner, the sudden release of pressure caused by the complete extrusion of the tubular member 210 off of the expandable mandrel 205 can be minimized. In a

preferred embodiment, the operating pressure is reduced in a substantially linear fashion from 100% to about 10% during the end of the extrusion process beginning when the mandrel 205 is within about 1.524 m (5 feet) from completion of the extrusion process.

5 Alternatively, or in combination, a shock absorber is provided in the support member 250 in order to absorb the shock caused by the sudden release of pressure. The shock absorber may comprise, for example, any conventional commercially available shock absorber adapted for use in wellbore operations.

10 Alternatively, or in combination, a mandrel catching structure is provided in the end portion 260 of the tubular member 210 in order to catch or at least decelerate the mandrel 205.

Once the extrusion process is completed, the expandable mandrel 205 is removed from the wellbore 100. In a preferred embodiment, either before or after the removal of the expandable mandrel 205, the integrity of the fluidic seal of the 15 overlapping joint between the upper portion 260 of the tubular member 210 and the lower portion 270 of the casing 115 is tested using conventional methods.

If the fluidic seal of the overlapping joint between the upper portion 260 of the tubular member 210 and the lower portion 270 of the casing 115 is satisfactory, then any uncured portion of the material 305 within the expanded tubular member 20 210 is then removed in a conventional manner such as, for example, circulating the uncured material out of the interior of the expanded tubular member 210. The mandrel 205 is then pulled out of the wellbore section 130 and a drill bit or mill is used in combination with a conventional drilling assembly 505 to drill out any hardened material 305 within the tubular member 210. The material 305 within 25 the annular region 315 is then allowed to cure.

As illustrated in Fig. 5, preferably any remaining cured material 305 within the interior of the expanded tubular member 210 is then removed in a conventional manner using a conventional drill string 505. The resulting new section of casing 510 includes the expanded tubular member 210 and an outer 30 annular layer 515 of cured material 305. The bottom portion of the apparatus 200 comprising the shoe 215 and dart 405 may then be removed by drilling out the shoe 215 and dart 405 using conventional drilling methods.

As illustrated in Fig. 6, the upper portion 260 of the tubular member 210 includes one or more sealing members 605 and one or more pressure relief holes 610. In this manner, the overlapping joint between the lower portion 270 of the casing 115 and the upper portion 260 of the tubular member 210 is pressure-tight and the pressure on the interior and exterior surfaces of the tubular member 210 is equalized during the extrusion process.

The sealing members 605 are seated within recesses 615 formed in the outer surface 265 of the upper portion 260 of the tubular member 210. In an alternative preferred embodiment, the sealing members 605 are bonded or molded onto the outer surface 265 of the upper portion 260 of the tubular member 210. The pressure relief holes 610 are preferably positioned in the last few feet of the tubular member 210. The pressure relief holes reduce the operating pressures required to expand the upper portion 260 of the tubular member 210. This reduction in required operating pressure in turn reduces the velocity of the mandrel 205 upon the completion of the extrusion process. This reduction in velocity in turn minimizes the mechanical shock to the entire apparatus 200 upon the completion of the extrusion process.

Referring now to Fig. 7, a particularly preferred embodiment of an apparatus 700 for forming a casing within a wellbore preferably includes an expandable mandrel or pig 705, an expandable mandrel or pig container 710, a tubular member 715, a float shoe 720, a lower cup seal 725, an upper cup seal 730, a fluid passage 735, a fluid passage 740, a support member 745, a body of lubricant 750, an overshot connection 755, another support member 760, and a stabilizer 765.

The expandable mandrel 705 is coupled to and supported by the support member 745. The expandable mandrel 705 is further coupled to the expandable mandrel container 710. The expandable mandrel 705 is preferably adapted to controllably expand in a radial direction. The expandable mandrel 705 may comprise any number of conventional commercially available expandable mandrels modified in accordance with the teachings of the present disclosure. In a preferred embodiment, the expandable mandrel 705 comprises a hydraulic expansion tool substantially as disclosed in U.S. Pat. No. 5,348,095, the contents of which are

incorporated herein by reference, modified in accordance with the teachings of the present disclosure.

The expandable mandrel container 710 is coupled to and supported by the support member 745. The expandable mandrel container 710 is further coupled
5 to the expandable mandrel 705. The expandable mandrel container 710 may be constructed from any number of conventional commercially available materials such as, for example, Oilfield Country Tubular Goods, stainless steel, titanium or high strength steels. In a preferred embodiment, the expandable mandrel container 710 is fabricated from material having a greater strength than the
10 material from which the tubular member 715 is fabricated. In this manner, the container 710 can be fabricated from a tubular material having a thinner wall thickness than the tubular member 210. This permits the container 710 to pass through tight clearances thereby facilitating its placement within the wellbore.

In a preferred embodiment, once the expansion process begins, and the
15 thicker, lower strength material of the tubular member 715 is expanded, the outside diameter of the tubular member 715 is greater than the outside diameter of the container 710.

The tubular member 715 is coupled to and supported by the expandable mandrel 705. The tubular member 715 is preferably expanded in the radial
20 direction and extruded off of the expandable mandrel 705 substantially as described above with reference to Figs. 1-6. The tubular member 715 may be fabricated from any number of materials such as, for example, Oilfield Country Tubular Goods (OCTG), automotive grade steel or plastics. In a preferred embodiment, the tubular member 715 is fabricated from OCTG.

25 In a preferred embodiment, the tubular member 715 has a substantially annular cross-section. In a particularly preferred embodiment, the tubular member 715 has a substantially circular annular cross-section.

The tubular member 715 preferably includes an upper section 805, an intermediate section 810, and a lower section 815. The upper section 805 of the
30 tubular member 715 preferably is defined by the region beginning in the vicinity of the mandrel container 710 and ending with the top section 820 of the tubular member 715. The intermediate section 810 of the tubular member 715 is

preferably defined by the region beginning in the vicinity of the top of the mandrel container 710 and ending with the region in the vicinity of the mandrel 705. The lower section of the tubular member 715 is preferably defined by the region beginning in the vicinity of the mandrel 705 and ending at the bottom 825 of the tubular member 715.

In a preferred embodiment, the wall thickness of the upper section 805 of the tubular member 715 is greater than the wall thicknesses of the intermediate and lower sections 810 and 815 of the tubular member 715 in order to optimally facilitate the initiation of the extrusion process and optimally permit the apparatus 700 to be positioned in locations in the wellbore having tight clearances.

The outer diameter and wall thickness of the upper section 805 of the tubular member 715 may range, for example, from about 2.667 to 121.92 cms (1.05 to 48 inches) and 0.3175 to 5.08 cms (1/8 to 2 inches), respectively. In a preferred embodiment, the outer diameter and wall thickness of the upper section 805 of the tubular member 715 range from about 8.89 to 40.64 cms (3.5 to 16 inches) and 0.375 to 3.81 cms (3/8 to 1.5 inches), respectively.

The outer diameter and wall thickness of the intermediate section 810 of the tubular member 715 may range, for example, from about 6.35 to 127 cms (2.5 to 50 inches) and 0.15875 to 3.81 cms (1/16 to 1.5 inches), respectively. In a preferred embodiment, the outer diameter and wall thickness of the intermediate section 810 of the tubular member 715 range from about 8.89 to 48.26 cms (3.5 to 19 inches) and 0.3175 to 3.175 cms (1/8 to 1.25 inches), respectively.

The outer diameter and wall thickness of the lower section 815 of the tubular member 715 may range, for example from about 6.35 to 127 cms (2.5 to 50 inches) and 0.15875 to 3.175 cms (1/16 to 1.25 inches), respectively. In a preferred embodiment, the outer diameter and wall thickness of the lower section 810 of the tubular member 715 range from about 8.89 to 48.26 cms (3.5 to 19 inches) and 0.3175 to 3.175 cms (1/8 to 1.25 inches), respectively. In a particularly preferred embodiment, the wall thickness of the lower section 815 of the tubular member 715 is further increased to increase the strength of the shoe 720 when drillable materials such as, for example, aluminium are used.

The tubular member 715 preferably comprises a solid tubular member. In a preferred embodiment, the end portion 820 of the tubular member 715 is slotted, perforated, or otherwise modified to catch or slow down the mandrel 705 when it completes the extrusion of tubular member 715. In a preferred embodiment, the

length of the tubular member 715 is limited to minimize the possibility of buckling. For typical tubular member 715 materials, the length of the tubular member 715 is preferably limited to between about 12.192 to 6,096 m (40 to 20,000 feet) in length.

The shoe 720 is coupled to the expandable mandrel 705 and the tubular member 715. The shoe 720 includes the fluid passage 740. In a preferred embodiment, the shoe 720 further includes an inlet passage 830, and one or more jet ports 835. In a particularly preferred embodiment, the cross-sectional shape of the inlet passage 830 is adapted to receive a latch-down dart, or other similar elements, for blocking the inlet passage 830. The interior of the shoe 720 preferably includes a body of solid material 840 for increasing the strength of the shoe 720. In a particularly preferred embodiment, the body of solid material 840 comprises aluminum.

The shoe 720 may comprise any number of conventional commercially available shoes such as, for example, Super Seal II Down-Jet float shoe, or guide shoe with a sealing sleeve for a latch down plug modified in accordance with the teachings of the present disclosure. In a preferred embodiment, the shoe 720 comprises an aluminum down-jet guide shoe with a sealing sleeve for a latch-down plug available from Halliburton Energy Services in Dallas, TX, modified in accordance with the teachings of the present disclosure, in order to optimize guiding the tubular member 715 in the wellbore, optimize the seal between the tubular member 715 and an existing wellbore casing, and to optimally facilitate the removal of the shoe 720 by drilling it out after completion of the extrusion process.

The lower cup seal 725 is coupled to and supported by the support member 745. The lower cup seal 725 prevents foreign materials from entering the interior region of the tubular member 715 above the expandable mandrel 705. The lower cup seal 725 may comprise any number of conventional commercially available cup seals such as, for example, TP cups or Selective Injection Packer (SIP) cups modified in accordance with the teachings of the present disclosure. In a preferred embodiment, the lower cup seal 725 comprises a SIP cup, available from Halliburton Energy Services in Dallas, TX in order to optimally provide a debris barrier and hold a body of lubricant.

The upper cup seal 730 is coupled to and supported by the support member 760. The upper cup seal 730 prevents foreign materials from entering the interior region of the tubular member 715. The upper cup seal 730 may comprise any number of conventional commercially available cup seals such as, for example, TP 5 cups or Selective Injection Packer (SIP) cup modified in accordance with the teachings of the present disclosure. In a preferred embodiment, the upper cup seal 730 comprises a SIP cup available from Halliburton Energy Services in Dallas, TX in order to optimally provide a debris barrier and contain a body of lubricant.

The fluid passage 735 permits fluidic materials to be transported to and 10 from the interior region of the tubular member 715 below the expandable mandrel 705. The fluid passage 735 is fluidically coupled to the fluid passage 740. The fluid passage 735 is preferably coupled to and positioned within the support member 760, the support member 745, the mandrel container 710, and the expandable mandrel 705. The fluid passage 735 preferably extends from a position adjacent 15 to the surface to the bottom of the expandable mandrel 705. The fluid passage 735 is preferably positioned along a centerline of the apparatus 700. The fluid passage 735 is preferably selected to transport materials such as cement, drilling mud or epoxies at flow rates and pressures ranging from about 151.4164 to 11356.2355 litres/minute (40 to 3,000 gallons/minute) and 34.473 to 620.52813 bar (500 to 9,000 psi) in order to provide sufficient operating 20 pressures to extrude the tubular member 715 off of the expandable mandrel 705.

As described above with reference to Figs. 1-6, during placement of the apparatus 700 within a new section of a wellbore, fluidic materials forced up the fluid passage 735 can be released into the wellbore above the tubular member 715. In a preferred embodiment, the apparatus 700 further includes a pressure release 25 passage that is coupled to and positioned within the support member 260. The pressure release passage is further fluidically coupled to the fluid passage 735. The pressure release passage preferably includes a control valve for controllably opening and closing the fluid passage. In a preferred embodiment, the control valve is pressure activated in order to controllably minimize surge pressures. The 30 pressure release passage is preferably positioned substantially orthogonal to the centerline of the apparatus 700. The pressure release passage is preferably selected to convey materials such as cement, drilling mud or epoxies at flow rates

and pressures ranging from about 0 to 1892.7059 litres/minute (0 to 500 gallons/minute) and 0 to 68.94757 bar (0 to 1,000 psi) in order to reduce the drag on the apparatus 700 during insertion into a new section of a wellbore and to minimize surge pressures on the new wellbore section.

5 The fluid passage 740 permits fluidic materials to be transported to and from the region exterior to the tubular member 715. The fluid passage 740 is preferably coupled to and positioned within the shoe 720 in fluidic communication with the interior region of the tubular member 715 below the expandable mandrel 705. The fluid passage 740 preferably has a cross-sectional shape that permits a plug, or other similar device, to be placed in the inlet 830 of the fluid passage 740
10 to thereby block further passage of fluidic materials. In this manner, the interior region of the tubular member 715 below the expandable mandrel 705 can be optimally fluidically isolated from the region exterior to the tubular member 715. This permits the interior region of the tubular member 715 below the expandable mandrel 205 to be pressurized.

15 The fluid passage 740 is preferably positioned substantially along the centerline of the apparatus 700. The fluid passage 740 is preferably selected to convey materials such as cement, drilling mud or epoxies at flow rates and pressures ranging from about 0 to 11356.2355 litres/minute (0 to 3,000 gallons/minute) and 0 to 620.52813 bar (0 to 9,000 psi) in order to optimally fill an annular region
20 between the tubular member 715 and a new section of a wellbore with fluidic materials. In a preferred embodiment, the fluid passage 740 includes an inlet passage 830 having a geometry that can receive a dart and/or a ball sealing member. In this manner, the fluid passage 240 can be sealed off by introducing a plug, dart and/or ball sealing elements into the fluid passage 230.

25 In a preferred embodiment, the apparatus 700 further includes one or more seals 845 coupled to and supported by the end portion 820 of the tubular member 715. The seals 845 are further positioned on an outer surface of the end portion 820 of the tubular member 715. The seals 845 permit the overlapping joint between an end portion of preexisting casing and the end portion 820 of the
30 tubular member 715 to be fluidically sealed. The seals 845 may comprise any number of conventional commercially available seals such as, for example, lead, rubber, Teflon™, or epoxy seals modified in accordance with the teachings of the

present disclosure. In a preferred embodiment, the seals 845 comprise seals molded from StrataLock epoxy available from Halliburton Energy Services in Dallas, TX in order to optimally provide a hydraulic seal and a load bearing interference fit in the overlapping joint between the tubular member 715 and an existing casing with optimal load bearing capacity to support the tubular member 715.

In a preferred embodiment, the seals 845 are selected to provide a sufficient frictional force to support the expanded tubular member 715 from the existing casing. In a preferred embodiment, the frictional force provided by the seals 845 ranges from about 68,947.57 to 68,947.57 bar (1,000 to 1,000, 000 lbf) in order to optimally support the expanded tubular member 715.

The support member 745 is preferably coupled to the expandable mandrel 705 and the overshot connection 755. The support member 745 preferably comprises an annular member having sufficient strength to carry the apparatus 700 into a new section of a wellbore. The support member 745 may comprise any number of conventional commercially available support members such as, for example, steel drill pipe, coiled tubing or other high strength tubular modified in accordance with the teachings of the present disclosure. In a preferred embodiment, the support member 745 comprises conventional drill pipe available from various steel mills in the United States.

In a preferred embodiment, a body of lubricant 750 is provided in the annular region above the expandable mandrel container 710 within the interior of the tubular member 715. In this manner, the extrusion of the tubular member 715 off of the expandable mandrel 705 is facilitated. The lubricant 705 may comprise any number of conventional commercially available lubricants such as, for example, Lubriplate, chlorine based lubricants, oil based lubricants, or Climax 1500 Antisieze (3100). In a preferred embodiment, the lubricant 750 comprises Climax 1500 Antisieze (3100) available from Halliburton Energy Services in Houston, TX in order to optimally provide lubrication to facilitate the extrusion process.

The overshot connection 755 is coupled to the support member 745 and the support member 760. The overshot connection 755 preferably permits the support

member 745 to be removably coupled to the support member 760. The overshot connection 755 may comprise any number of conventional commercially available overshot connections such as, for example, Innerstring Sealing Adapter, Innerstring Flat-Face Sealing Adapter or EZ Drill Setting Tool Stinger. In a preferred embodiment, the overshot connection 755 comprises a Innerstring Adapter with an Upper Guide available from Halliburton Energy Services in Dallas, TX.

The support member 760 is preferably coupled to the overshot connection 755 and a surface support structure (not illustrated). The support member 760 preferably comprises an annular member having sufficient strength to carry the apparatus 700 into a new section of a wellbore. The support member 760 may comprise any number of conventional commercially available support members such as, for example, steel drill pipe, coiled tubing or other high strength tubulars modified in accordance with the teachings of the present disclosure. In a preferred embodiment, the support member 760 comprises a conventional drill pipe available from steel mills in the United States.

The stabilizer 765 is preferably coupled to the support member 760. The stabilizer 765 also preferably stabilizes the components of the apparatus 700 within the tubular member 715. The stabilizer 765 preferably comprises a spherical member having an outside diameter that is about 80 to 99% of the interior diameter of the tubular member 715 in order to optimally minimize buckling of the tubular member 715. The stabilizer 765 may comprise any number of conventional commercially available stabilizers such as, for example, EZ Drill Star Guides, packer shoes or drag blocks modified in accordance with the teachings of the present disclosure. In a preferred embodiment, the stabilizer 765 comprises a sealing adapter upper guide available from Halliburton Energy Services in Dallas, TX.

In a preferred embodiment, the support members 745 and 760 are thoroughly cleaned prior to assembly to the remaining portions of the apparatus 700. In this manner, the introduction of foreign material into the apparatus 700 is minimized. This minimizes the possibility of foreign material clogging the various flow passages and valves of the apparatus 700.

In a preferred embodiment, before or after positioning the apparatus 700 within a new section of a wellbore, a couple of wellbore volumes are circulated through the various flow passages of the apparatus 700 in order to ensure that no foreign materials are located within the wellbore that might clog up the various flow passages and valves of the apparatus 700 and to ensure that no foreign material interferes with the expansion mandrel 705 during the expansion process.

In a preferred embodiment, the apparatus 700 is operated substantially as described above with reference to Figs. 1-7 to form a new section of casing within a wellbore.

As illustrated in Fig. 8, in an alternative preferred embodiment, the method and apparatus described herein is used to repair an existing wellbore casing 805 by forming a tubular liner 810 inside of the existing wellbore casing 805. In a preferred embodiment, an outer annular lining of cement is not provided in the repaired section. In the alternative preferred embodiment, any number of fluidic materials can be used to expand the tubular liner 810 into intimate contact with the damaged section of the wellbore casing such as, for example, cement, epoxy, slag mix, or drilling mud. In the alternative preferred embodiment, sealing members 815 are preferably provided at both ends of the tubular member in order to optimally provide a fluidic seal. In an alternative preferred embodiment, the tubular liner 810 is formed within a horizontally positioned pipeline section, such as those used to transport hydrocarbons or water, with the tubular liner 810 placed in an overlapping relationship with the adjacent pipeline section. In this manner, underground pipelines can be repaired without having to dig out and replace the damaged sections.

In another alternative preferred embodiment, the method and apparatus described herein is used to directly line a wellbore with a tubular liner 810. In a preferred embodiment, an outer annular lining of cement is not provided between the tubular liner 810 and the wellbore. In the alternative preferred embodiment, any number of fluidic materials can be used to expand the tubular liner 810 into intimate contact with the wellbore such as, for example, cement, epoxy, slag mix, or drilling mud.

Referring now to Figs. 9, 9a, 9b and 9c, a preferred embodiment of an apparatus 900 for forming a wellbore casing includes an expandible tubular member 902, a support member 904, an expandible mandrel or pig 906, and a shoe 908. In a preferred embodiment, the design and construction of the mandrel 906 and shoe 908 permits easy removal of those elements by drilling them out. In this manner, the assembly 900 can be easily removed from a wellbore using a conventional drilling apparatus and corresponding drilling methods.

The expandible tubular member 902 preferably includes an upper portion 910, an intermediate portion 912 and a lower portion 914. During operation of the apparatus 900, the tubular member 902 is preferably extruded off of the mandrel 906 by pressurizing an interior region 966 of the tubular member 902. The tubular member 902 preferably has a substantially annular cross-section.

In a particularly preferred embodiment, an expandable tubular member 915 is coupled to the upper portion 910 of the expandable tubular member 902. During operation of the apparatus 900, the tubular member 915 is preferably extruded off of the mandrel 906 by pressurizing the interior region 966 of the tubular member 902. The tubular member 915 preferably has a substantially annular cross-section. In a preferred embodiment, the wall thickness of the tubular member 915 is greater than the wall thickness of the tubular member 902.

The tubular member 915 may be fabricated from any number of conventional commercially available materials such as, for example, oilfield tubulars, low alloy steels, titanium or stainless steels. In a preferred embodiment, the tubular member 915 is fabricated from oilfield tubulars in order to optimally provide approximately the same mechanical properties as the tubular member 902. In a particularly preferred embodiment, the tubular member 915 has a plastic yield point ranging from about 275.9028 to 9307.92195 bar (40,000 to 135,000 psi) in order to optimally provide approximately the same yield properties as the tubular member 902. The tubular member 915 comprise a plurality of tubular members coupled end to end.

In a preferred embodiment, the upper end portion of the tubular member 915 includes one or more sealing members for optimally providing a fluidic and/or gaseous seal with an existing section of wellbore casing.

In a preferred embodiment, the combined length of the tubular members 902 and 915 are limited to minimize the possibility of buckling. For typical tubular member materials, the combined length of the tubular members 902 and 915 are limited to between about 12.192 to 6,096m (40 to 20,000 feet) in length.

The lower portion 914 of the tubular member 902 is preferably coupled to the shoe 908 by a threaded connection 968. The intermediate portion 912 of the tubular member 902 preferably is placed in intimate sliding contact with the mandrel 906.

The tubular member 902 may be fabricated from any number of conventional commercially available materials such as, for example, oilfield tubulars, low alloy steels, titanium or stainless steels. In a preferred embodiment, the tubular member 902 is fabricated from oilfield tubulars in order to optimally provide approximately the same mechanical properties as the tubular member 915. In a particularly preferred embodiment, the tubular member 902 has a plastic yield point ranging from about 275.9028 to 9307.92195 bar (40,000 to 135,000) psi in order to optimally provide approximately the same yield properties as the tubular member 915.

The wall thickness of the upper, intermediate, and lower portions, 910, 912 and 914 of the tubular member 902 may range, for example, from about 0.625 to 3.81 cms (1/16 to 1.5 inches). In a preferred embodiment, the wall thickness of the upper, intermediate, and lower portions, 910, 912 and 914 of the tubular member 902 range from about 0.3175 to 3.175 cms (1/8 to 1.25 inches) in order to optimally provide wall thickness that are about the same as the tubular member 915. In a preferred embodiment, the wall thickness of the lower portion 914 is less than or equal to the wall thickness of the upper portion 910 in order to optimally provide a geometry that will fit into tight clearances downhole.

The outer diameter of the upper, intermediate, and lower portions, 910, 912 and 914 of the tubular member 902 may range, for example, from about 2.667 to 121.92 cms (1.05 to 48 inches). In a preferred embodiment, the outer diameter of the upper, intermediate, and lower portions, 910, 912 and 914 of the tubular member 902 range from about 8.89 to 48.26 cms (3 ½ to 19 inches) in order to optimally provide the ability to expand the most commonly used oilfield tubulars.

The length of the tubular member 902 is preferably limited to between about 0.6096 to 1.524 m (2 to 5 feet) in order to optimally provide enough length to contain the mandrel 906 and a body of lubricant.

The tubular member 902 may comprise any number of conventional
5 commercially available tubular members modified in accordance with the teachings of the present disclosure. In a preferred embodiment, the tubular member 902 comprises Oilfield Country Tubular Goods available from various U.S. steel mills. The tubular member 915 may comprise any number of conventional commercially available tubular members modified in accordance with the teachings of the
10 present disclosure. In a preferred embodiment, the tubular member 915 comprises Oilfield Country Tubular Goods available from various U.S. steel mills.

The various elements of the tubular member 902 may be coupled using any number of conventional process such as, for example, threaded connections, welding or machined from one piece. In a preferred embodiment, the various
15 elements of the tubular member 902 are coupled using welding. The tubular member 902 may comprise a plurality of tubular elements that are coupled end to end. The various elements of the tubular member 915 may be coupled using any number of conventional process such as, for example, threaded connections, welding or machined from one piece. In a preferred embodiment, the various
20 elements of the tubular member 915 are coupled using welding. The tubular member 915 may comprise a plurality of tubular elements that are coupled end to end. The tubular members 902 and 915 may be coupled using any number of conventional process such as, for example, threaded connections, welding or machined from one piece.

25 The support member 904 preferably includes an innerstring adapter 916, a fluid passage 918, an upper guide 920, and a coupling 922. During operation of the apparatus 900, the support member 904 preferably supports the apparatus 900 during movement of the apparatus 900 within a wellbore. The support member 904 preferably has a substantially annular cross-section.

30 The support member 904 may be fabricated from any number of conventional commercially available materials such as, for example, oilfield tubulars, low alloy steel, coiled tubing or stainless steel. In a preferred

embodiment, the support member 904 is fabricated from low alloy steel in order to optimally provide high yield strength.

The innerstring adaptor 916 preferably is coupled to and supported by a conventional drill string support from a surface location. The innerstring adaptor 5 916 may be coupled to a conventional drill string support 971 by a threaded connection 970.

The fluid passage 918 is preferably used to convey fluids and other materials to and from the apparatus 900. In a preferred embodiment, the fluid passage 918 is fluidically coupled to the fluid passage 952. In a preferred embodiment, the fluid 10 passage 918 is used to convey hardenable fluidic sealing materials to and from the apparatus 900. In a particularly preferred embodiment, the fluid passage 918 may include one or more pressure relief passages (not illustrated) to release fluid pressure during positioning of the apparatus 900 within a wellbore. In a preferred embodiment, the fluid passage 918 is positioned along a longitudinal centerline of 15 the apparatus 900. In a preferred embodiment, the fluid passage 918 is selected to permit the conveyance of hardenable fluidic materials at operating pressures ranging from about 0 to 620.52813 bar (0 to 9,000 psi).

The upper guide 920 is coupled to an upper portion of the support member 904. The upper guide 920 preferably is adapted to center the support member 904 20 within the tubular member 915. The upper guide 920 may comprise any number of conventional guide members modified in accordance with the teachings of the present disclosure. In a preferred embodiment, the upper guide 920 comprises an innerstring adapter available from Halliburton Energy Services in Dallas, TX order to optimally guide the apparatus 900 within the tubular member 915.

25 The coupling 922 couples the support member 904 to the mandrel 906. The coupling 922 preferably comprises a conventional threaded connection.

The various elements of the support member 904 may be coupled using any number of conventional processes such as, for example, welding, threaded connections or machined from one piece. In a preferred embodiment, the various 30 elements of the support member 904 are coupled using threaded connections.

The mandrel 906 preferably includes a retainer 924, a rubber cup 926, an expansion cone 928, a lower cone retainer 930, a body of cement 932, a lower guide

934, an extension sleeve 936, a spacer 938, a housing 940, a sealing sleeve 942, an upper cone retainer 944, a lubricator mandrel 946, a lubricator sleeve 948, a guide 950, and a fluid passage 952.

The retainer 924 is coupled to the lubricator mandrel 946, lubricator sleeve 5 948, and the rubber cup 926. The retainer 924 couples the rubber cup 926 to the lubricator sleeve 948. The retainer 924 preferably has a substantially annular cross-section. The retainer 924 may comprise any number of conventional commercially available retainers such as, for example, slotted spring pins or roll pin.

10 The rubber cup 926 is coupled to the retainer 924, the lubricator mandrel 946, and the lubricator sleeve 948. The rubber cup 926 prevents the entry of foreign materials into the interior region 972 of the tubular member 902 below the rubber cup 926. The rubber cup 926 may comprise any number of conventional commercially available rubber cups such as, for example, TP cups or Selective
15 Injection Packer (SIP) cup. In a preferred embodiment, the rubber cup 926 comprises a SIP cup available from Halliburton Energy Services in Dallas, TX in order to optimally block foreign materials.

In a particularly preferred embodiment, a body of lubricant is further provided in the interior region 972 of the tubular member 902 in order to lubricate
20 the interface between the exterior surface of the mandrel 902 and the interior surface of the tubular members 902 and 915. The lubricant may comprise any number of conventional commercially available lubricants such as, for example, Lubriplate™, chlorine based lubricants, oil based lubricants or Climax 1500 Antiseize (3100). In a preferred embodiment, the lubricant comprises Climax 1500 Antiseize
25 (3100) available from Climax Lubricants and Equipment Co. in Houston, TX in order to optimally provide lubrication to facilitate the extrusion process.

The expansion cone 928 is coupled to the lower cone retainer 930, the body of cement 932, the lower guide 934, the extension sleeve 936, the housing 940, and the upper cone retainer 944. In a preferred embodiment, during operation of the
30 apparatus 900, the tubular members 902 and 915 are extruded off of the outer surface of the expansion cone 928. In a preferred embodiment, axial movement of the expansion cone 928 is prevented by the lower con retainer 930, housing 940

and the upper cone retainer 944. Inner radial movement of the expansion cone 928 is prevented by the body of cement 932, the housing 940, and the upper cone retainer 944.

The expansion cone 928 preferably has a substantially annular cross section.

5 The outside diameter of the expansion cone 928 is preferably tapered to provide a cone shape. The wall thickness of the expansion cone 928 may range, for example, from about 0.3175 to 7.62 cms (0.125 to 3 inches). In a preferred embodiment, the wall thickness of the expansion cone 928 ranges from about 0.635 to 1.905 cms (0.25 to 0.75 inches) in order to optimally provide adequate compressive strength with minimal material. The maximum and minimum outside
10 diameters of the expansion cone 928 may range, for example, from about 2.54 to 119.38 cms (1 to 47 inches). In a preferred embodiment, the maximum and minimum outside diameters of the expansion cone 928 range from about 8.89 to 48.26 cms (3.5 to 19 inches) in order to optimally provide expansion of generally available oilfield tubulars.

The expansion cone 928 may be fabricated from any number of conventional
15 commercially available materials such as, for example, ceramic, tool steel, titanium or low alloy steel. In a preferred embodiment, the expansion cone 928 is fabricated from tool steel in order to optimally provide high strength and abrasion resistance. The surface hardness of the outer surface of the expansion cone 928 may range, for example, from about 50 Rockwell C to 70 Rockwell C. In a preferred embodiment,
20 the surface hardness of the outer surface of the expansion cone 928 ranges from about 58 Rockwell C to 62 Rockwell C in order to optimally provide high yield strength. In a preferred embodiment, the expansion cone 928 is heat treated to optimally provide a hard outer surface and a resilient interior body in order to optimally provide abrasion resistance and fracture toughness.

25 The lower cone retainer 930 is coupled to the expansion cone 928 and the housing 940. In a preferred embodiment, axial movement of the expansion cone 928 is prevented by the lower cone retainer 930. Preferably, the lower cone retainer 930 has a substantially annular cross-section.

The lower cone retainer 930 may be fabricated from any number of
30 conventional commercially available materials such as, for example, ceramic, tool steel, titanium or low alloy steel. In a preferred embodiment, the lower cone retainer 930 is fabricated from tool steel in order to optimally provide high

strength and abrasion resistance. The surface hardness of the outer surface of the lower cone retainer 930 may range, for example, from about 50 Rockwell C to 70 Rockwell C. In a preferred embodiment, the surface hardness of the outer surface of the lower cone retainer 930 ranges from about 58 Rockwell C to 62 Rockwell C in order to optimally provide high yield strength. In a preferred embodiment, the lower cone retainer 930 is heat treated to optimally provide a hard outer surface and a resilient interior body in order to optimally provide abrasion resistance and fracture toughness.

In a preferred embodiment, the lower cone retainer 930 and the expansion cone 928 are formed as an integral one-piece element in order to reduce the number of components and increase the overall strength of the apparatus. The outer surface of the lower cone retainer 930 preferably mates with the inner surfaces of the tubular members 902 and 915.

The body of cement 932 is positioned within the interior of the mandrel 906. The body of cement 932 provides an inner bearing structure for the mandrel 906. The body of cement 932 further may be easily drilled out using a conventional drill device. In this manner, the mandrel 906 may be easily removed using a conventional drilling device.

The body of cement 932 may comprise any number of conventional commercially available cement compounds. Alternatively, aluminum, cast iron or some other drillable metallic, composite, or aggregate material may be substituted for cement. The body of cement 932 preferably has a substantially annular cross-section.

The lower guide 934 is coupled to the extension sleeve 936 and housing 940. During operation of the apparatus 900, the lower guide 934 preferably helps guide the movement of the mandrel 906 within the tubular member 902. The lower guide 934 preferably has a substantially annular cross-section.

The lower guide 934 may be fabricated from any number of conventional commercially available materials such as, for example, oilfield tubulars, low alloy steel or stainless steel. In a preferred embodiment, the lower guide 934 is fabricated from low alloy steel in order to optimally provide high yield strength.

(
The outer surface of the lower guide 934 preferably mates with the inner surface of the tubular member 902 to provide a sliding fit.

The extension sleeve 936 is coupled to the lower guide 934 and the housing 940. During operation of the apparatus 900, the extension sleeve 936 preferably helps guide the movement of the mandrel 906 within the tubular member 902. The extension sleeve 936 preferably has a substantially annular cross-section.

The extension sleeve 936 may be fabricated from any number of conventional commercially available materials such as, for example, oilfield tubulars, low alloy steel or stainless steel. In a preferred embodiment, the extension sleeve 936 is fabricated from low alloy steel in order to optimally provide high yield strength. The outer surface of the extension sleeve 936 preferably mates with the inner surface of the tubular member 902 to provide a sliding fit. In a preferred embodiment, the extension sleeve 936 and the lower guide 934 are formed as an integral one-piece element in order to minimize the number of components and increase the strength of the apparatus.

The spacer 938 is coupled to the sealing sleeve 942. The spacer 938 preferably includes the fluid passage 952 and is adapted to mate with the extension tube 960 of the shoe 908. In this manner, a plug or dart can be conveyed from the surface through the fluid passages 918 and 952 into the fluid passage 962. Preferably, the spacer 938 has a substantially annular cross-section.

The spacer 938 may be fabricated from any number of conventional commercially available materials such as, for example, steel, aluminum or cast iron. In a preferred embodiment, the spacer 938 is fabricated from aluminum in order to optimally provide drillability. The end of the spacer 938 preferably mates with the end of the extension tube 960. In a preferred embodiment, the spacer 938 and the sealing sleeve 942 are formed as an integral one-piece element in order to reduce the number of components and increase the strength of the apparatus.

The housing 940 is coupled to the lower guide 934, extension sleeve 936, expansion cone 928, body of cement 932, and lower cone retainer 930. During operation of the apparatus 900, the housing 940 preferably prevents inner radial motion of the expansion cone 928. Preferably, the housing 940 has a substantially annular cross-section.

The housing 940 may be fabricated from any number of conventional commercially available materials such as, for example, oilfield tubulars, low alloy steel or stainless steel. In a preferred embodiment, the housing 940 is fabricated from low alloy steel in order to optimally provide high yield strength. In a 5 preferred embodiment, the lower guide 934, extension sleeve 936 and housing 940 are formed as an integral one-piece element in order to minimize the number of components and increase the strength of the apparatus.

In a particularly preferred embodiment, the interior surface of the housing 940 includes one or more protrusions to facilitate the connection between the 10 housing 940 and the body of cement 932.

The sealing sleeve 942 is coupled to the support member 904, the body of cement 932, the spacer 938, and the upper cone retainer 944. During operation of the apparatus, the sealing sleeve 942 preferably provides support for the mandrel 906. The sealing sleeve 942 is preferably coupled to the support member 904 using 15 the coupling 922. Preferably, the sealing sleeve 942 has a substantially annular cross-section.

The sealing sleeve 942 may be fabricated from any number of conventional commercially available materials such as, for example, steel, aluminum or cast iron. In a preferred embodiment, the sealing sleeve 942 is fabricated from 20 aluminum in order to optimally provide drillability of the sealing sleeve 942.

In a particularly preferred embodiment, the outer surface of the sealing sleeve 942 includes one or more protrusions to facilitate the connection between the sealing sleeve 942 and the body of cement 932.

In a particularly preferred embodiment, the spacer 938 and the sealing 25 sleeve 942 are integrally formed as a one-piece element in order to minimize the number of components.

The upper cone retainer 944 is coupled to the expansion cone 928, the sealing sleeve 942, and the body of cement 932. During operation of the apparatus 900, the upper cone retainer 944 preferably prevents axial motion of the expansion 30 cone 928. Preferably, the upper cone retainer 944 has a substantially annular cross-section.

The upper cone retainer 944 may be fabricated from any number of conventional commercially available materials such as, for example, steel, aluminum or cast iron. In a preferred embodiment, the upper cone retainer 944 is fabricated from aluminum in order to optimally provide drillability of the upper
5 cone retainer 944.

In a particularly preferred embodiment, the upper cone retainer 944 has a cross-sectional shape designed to provide increased rigidity. In a particularly preferred embodiment, the upper cone retainer 944 has a cross-sectional shape that is substantially I-shaped to provide increased rigidity and minimize the
10 amount of material that would have to be drilled out.

The lubricator mandrel 946 is coupled to the retainer 924, the rubber cup 926, the upper cone retainer 944, the lubricator sleeve 948, and the guide 950. During operation of the apparatus 900, the lubricator mandrel 946 preferably contains the body of lubricant in the annular region 972 for lubricating the
15 interface between the mandrel 906 and the tubular member 902. Preferably, the lubricator mandrel 946 has a substantially annular cross-section.

The lubricator mandrel 946 may be fabricated from any number of conventional commercially available materials such as, for example, steel, aluminum or cast iron. In a preferred embodiment, the lubricator mandrel 946 is
20 fabricated from aluminum in order to optimally provide drillability of the lubricator mandrel 946.

The lubricator sleeve 948 is coupled to the lubricator mandrel 946, the retainer 924, the rubber cup 926, the upper cone retainer 944, the lubricator sleeve 948, and the guide 950. During operation of the apparatus 900, the lubricator
25 sleeve 948 preferably supports the rubber cup 926. Preferably, the lubricator sleeve 948 has a substantially annular cross-section.

The lubricator sleeve 948 may be fabricated from any number of conventional commercially available materials such as, for example, steel, aluminum or cast iron. In a preferred embodiment, the lubricator sleeve 948 is
30 fabricated from aluminum in order to optimally provide drillability of the lubricator sleeve 948.

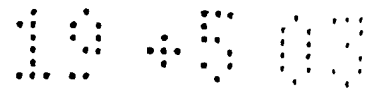

As illustrated in Fig. 9c, the lubricator sleeve 948 is supported by the lubricator mandrel 946. The lubricator sleeve 948 in turn supports the rubber cup 926. The retainer 924 couples the rubber cup 926 to the lubricator sleeve 948. In a preferred embodiment, seals 949a and 949b are provided between the lubricator mandrel 946, lubricator sleeve 948, and rubber cup 926 in order to optimally seal off the interior region 972 of the tubular member 902.

The guide 950 is coupled to the lubricator mandrel 946, the retainer 924, and the lubricator sleeve 948. During operation of the apparatus 900, the guide 950 preferably guides the apparatus on the support member 904. Preferably, the guide 950 has a substantially annular cross-section.

The guide 950 may be fabricated from any number of conventional commercially available materials such as, for example, steel, aluminum or cast iron. In a preferred embodiment, the guide 950 is fabricated from aluminum order to optimally provide drillability of the guide 950.

The fluid passage 952 is coupled to the mandrel 906. During operation of the apparatus, the fluid passage 952 preferably conveys hardenable fluidic materials. In a preferred embodiment, the fluid passage 952 is positioned about the centerline of the apparatus 900. In a particularly preferred embodiment, the fluid passage 952 is adapted to convey hardenable fluidic materials at pressures and flow rate ranging from about 0 to 620.52813 bar (0 to 9,000 psi) and 0 to 11356.2355 litres/minutes (0 to 3,000 gallons/min) in order to optimally provide pressures and flow rates to displace and circulate fluids during the installation of the apparatus 900.

The various elements of the mandrel 906 may be coupled using any number of conventional process such as, for example, threaded connections, welded connections or cementing. In a preferred embodiment, the various elements of the mandrel 906 are coupled using threaded connections and cementing.

The shoe 908 preferably includes a housing 954, a body of cement 956, a sealing sleeve 958, an extension tube 960, a fluid passage 962, and one or more outlet jets 964.

The housing 954 is coupled to the body of cement 956 and the lower portion 914 of the tubular member 902. During operation of the apparatus 900, the housing 954 preferably couples the lower portion of the tubular member 902 to the

shoe 908 to facilitate the extrusion and positioning of the tubular member 902. Preferably, the housing 954 has a substantially annular cross-section.

The housing 954 may be fabricated from any number of conventional commercially available materials such as, for example, steel or aluminum. In a preferred embodiment, the housing 954 is fabricated from aluminum in order to optimally provide drillability of the housing 954.

In a particularly preferred embodiment, the interior surface of the housing 954 includes one or more protrusions to facilitate the connection between the body of cement 956 and the housing 954.

10 The body of cement 956 is coupled to the housing 954, and the sealing sleeve 958. In a preferred embodiment, the composition of the body of cement 956 is selected to permit the body of cement to be easily drilled out using conventional drilling machines and processes.

The composition of the body of cement 956 may include any number of 15 conventional cement compositions. In an alternative embodiment, a drillable material such as, for example, aluminum or iron may be substituted for the body of cement 956.

The sealing sleeve 958 is coupled to the body of cement 956, the extension tube 960, the fluid passage 962, and one or more outlet jets 964. During operation 20 of the apparatus 900, the sealing sleeve 958 preferably is adapted to convey a hardenable fluidic material from the fluid passage 952 into the fluid passage 962 and then into the outlet jets 964 in order to inject the hardenable fluidic material into an annular region external to the tubular member 902. In a preferred embodiment, during operation of the apparatus 900, the sealing sleeve 958 further 25 includes an inlet geometry that permits a conventional plug or dart 974 to become lodged in the inlet of the sealing sleeve 958. In this manner, the fluid passage 962 may be blocked thereby fluidically isolating the interior region 966 of the tubular member 902.

In a preferred embodiment, the sealing sleeve 958 has a substantially 30 annular cross-section. The sealing sleeve 958 may be fabricated from any number of conventional commercially available materials such as, for example, steel, aluminum or cast iron. In a preferred embodiment, the sealing sleeve 958 is

fabricated from aluminum in order to optimally provide drillability of the sealing sleeve 958.

The extension tube 960 is coupled to the sealing sleeve 958, the fluid passage 962, and one or more outlet jets 964. During operation of the apparatus 5 900, the extension tube 960 preferably is adapted to convey a hardenable fluidic material from the fluid passage 952 into the fluid passage 962 and then into the outlet jets 964 in order to inject the hardenable fluidic material into an annular region external to the tubular member 902. In a preferred embodiment, during operation of the apparatus 900, the sealing sleeve 960 further includes an inlet 10 geometry that permits a conventional plug or dart 974 to become lodged in the inlet of the sealing sleeve 958. In this manner, the fluid passage 962 is blocked thereby fluidically isolating the interior region 966 of the tubular member 902. In a preferred embodiment, one end of the extension tube 960 mates with one end of the spacer 938 in order to optimally facilitate the transfer of material between the 15 two.

In a preferred embodiment, the extension tube 960 has a substantially annular cross-section. The extension tube 960 may be fabricated from any number of conventional commercially available materials such as, for example, steel, aluminum or cast iron. In a preferred embodiment, the extension tube 960 is 20 fabricated from aluminum in order to optimally provide drillability of the extension tube 960.

The fluid passage 962 is coupled to the sealing sleeve 958, the extension tube 960, and one or more outlet jets 964. During operation of the apparatus 900, the fluid passage 962 is preferably conveys hardenable fluidic materials. In a 25 preferred embodiment, the fluid passage 962 is positioned about the centerline of the apparatus 900. In a particularly preferred embodiment, the fluid passage 962 is adapted to convey hardenable fluidic materials at pressures and flow rate ranging from about 0 to 620.52813 bar (0 to 9,000 psi) and 0 to 11356.2355 (0 to 3,000 gallons/min) in order to optimally provide fluids at operationally efficient rates.

30 The outlet jets 964 are coupled to the sealing sleeve 958, the extension tube 960, and the fluid passage 962. During operation of the apparatus 900, the outlet jets 964 preferably convey hardenable fluidic material from the fluid passage 962

to the region exterior of the apparatus 900. In a preferred embodiment, the shoe 908 includes a plurality of outlet jets 964.

In a preferred embodiment, the outlet jets 964 comprise passages drilled in the housing 954 and the body of cement 956 in order to simplify the construction of the apparatus 900.

The various elements of the shoe 908 may be coupled using any number of conventional process such as, for example, threaded connections, cement or machined from one piece of material. In a preferred embodiment, the various elements of the shoe 908 are coupled using cement.

10 In a preferred embodiment, the assembly 900 is operated substantially as described above with reference to Figs. 1-8 to create a new section of casing in a wellbore or to repair a wellbore casing or pipeline.

In particular, in order to extend a wellbore into a subterranean formation, a drill string is used in a well known manner to drill out material from the 15 subterranean formation to form a new section.

The apparatus 900 for forming a wellbore casing in a subterranean formation is then positioned in the new section of the wellbore. In a particularly preferred embodiment, the apparatus 900 includes the tubular member 915. In a preferred embodiment, a hardenable fluidic sealing hardenable fluidic sealing 20 material is then pumped from a surface location into the fluid passage 918. The hardenable fluidic sealing material then passes from the fluid passage 918 into the interior region 966 of the tubular member 902 below the mandrel 906. The hardenable fluidic sealing material then passes from the interior region 966 into the fluid passage 962. The hardenable fluidic sealing material then exits the 25 apparatus 900 via the outlet jets 964 and fills an annular region between the exterior of the tubular member 902 and the interior wall of the new section of the wellbore. Continued pumping of the hardenable fluidic sealing material causes the material to fill up at least a portion of the annular region.

The hardenable fluidic sealing material is preferably pumped into the 30 annular region at pressures and flow rates ranging, for example, from about 0 to 344.73785 bar (0 to 5,000 psi) and 0 to 5678.1177 litres/minute (0 to 1,500 gallons/min), respectively. In a preferred embodiment, the hardenable fluidic sealing material is pumped into the annular region at pressures

and flow rates that are designed for the specific wellbore section in order to optimize the displacement of the hardenable fluidic sealing material while not creating high enough circulating pressures such that circulation might be lost and that could cause the wellbore to collapse. The optimum pressures and flow rates
5 are preferably determined using conventional empirical methods.

The hardenable fluidic sealing material may comprise any number of conventional commercially available hardenable fluidic sealing materials such as, for example, slag mix, cement or epoxy. In a preferred embodiment, the hardenable fluidic sealing material comprises blended cements designed
10 specifically for the well section being lined available from Halliburton Energy Services in Dallas, TX in order to optimally provide support for the new tubular member while also maintaining optimal flow characteristics so as to minimize operational difficulties during the displacement of the cement in the annular region. The optimum composition of the blended cements is preferably determined
15 using conventional empirical methods.

The annular region preferably is filled with the hardenable fluidic sealing material in sufficient quantities to ensure that, upon radial expansion of the tubular member 902, the annular region of the new section of the wellbore will be filled with hardenable material.

20 Once the annular region has been adequately filled with hardenable fluidic sealing material, a plug or dart 974, or other similar device, preferably is introduced into the fluid passage 962 thereby fluidically isolating the interior region 966 of the tubular member 902 from the external annular region. In a preferred embodiment, a non hardenable fluidic material is then pumped into the interior
25 region 966 causing the interior region 966 to pressurize. In a particularly preferred embodiment, the plug or dart 974, or other similar device, preferably is introduced into the fluid passage 962 by introducing the plug or dart 974, or other similar device into the non hardenable fluidic material. In this manner, the amount of cured material within the interior of the tubular members 902 and 915
30 is minimized.

Once the interior region 966 becomes sufficiently pressurized, the tubular members 902 and 915 are extruded off of the mandrel 906. The mandrel 906 may

b fixed or it may be expandible. During the extrusion process, the mandrel 906 is raised out of the expanded portions of the tubular members 902 and 915 using the support member 904. During this extrusion process, the shoe 908 is preferably substantially stationary.

5 The plug or dart 974 is preferably placed into the fluid passage 962 by introducing the plug or dart 974 into the fluid passage 918 at a surface location in a conventional manner. The plug or dart 974 may comprise any number of conventional commercially available devices for plugging a fluid passage such as, for example, Multiple Stage Cementer (MSC) latch-down plug, Omega latch-down
10 plug or three-wiper latch down plug modified in accordance with the teachings of the present disclosure. In a preferred embodiment, the plug or dart 974 comprises a MSC latch-down plug available from Halliburton Energy Services in Dallas, TX.

After placement of the plug or dart 974 in the fluid passage 962, the non
15 hardenable fluidic material is preferably pumped into the interior region 966 at pressures and flow rates ranging from approximately 34.473 to 620.52813 bar (500 to 9,000 psi) and 151.4164 to 11356.2355 litres/minute (40 to 3,000 gallons/min) in order to optimally extrude the tubular members 902 and 915 off of the mandrel 906.

For typical tubular members 902 and 915, the extrusion of the tubular members 902 and 915 off
of the expandable mandrel will begin when the pressure of the interior region 966 reaches approximately
20 34.473 to 620.52813 bar (500 to 9,000 psi). In a preferred embodiment, the extrusion of the tubular members 902 and 915 off of the mandrel 906 begins when the pressure of the interior region 966 reaches approximately 82.7352 to 586.041 bar (1,200 to 8,500 psi) with a flow rate of about 151.4164 to 4731.7648 litres/minute (40 to 1250 gallons/minute).

During the extrusion process, the mandrel 906 may be raised out of the expanded
25 portions of the tubular members 902 and 915 at rates ranging, for example, from about 0 to 1.524 m/s (0 to 5 ft/sec). In a preferred embodiment, during the extrusion process, the mandrel 906 is raised out of the expanded portions of the tubular members 902 and 915 at rates ranging from about 0 to 0.6096 m/s (0 to 2 ft/sec) in order to optimally provide pulling speed fast enough to permit efficient operation and permit full expansion of the tubular members 902 and 915 prior to curing of the hardenable fluidic sealing material; but not so fast that timely adjustment of operating parameters during operation is
30 prevented.

When the upper end portion of the tubular member 915 is extruded off of the mandrel 906, the outer surface of the upper end portion of the tubular member 915 will preferably contact the interior surface of the lower end portion of the existing casing to form a fluid tight overlapping joint. The contact pressure of the overlapping joint may range, for example, from approximately 3.447379 to 1,278.9514 bar (50 to 20,000 psi). In a preferred embodiment, the contact pressure of the overlapping joint between the upper end of the tubular member 915 and the existing section of wellbore casing ranges from approximately 27.579028 to 689.4757 bar (400 to 10,000 psi) in order to optimally provide contact pressure to activate the sealing members and provide optimal resistance such that the tubular member 915 existing wellbore casing will carry typical tensile and compressive loads.

In a preferred embodiment, the operating pressure and flow rate of the non hardenable fluidic material will be controllably ramped down when the mandrel 906 reaches the upper end portion of the tubular member 915. In this manner, the sudden release of pressure caused by the complete extrusion of the tubular member 915 off of the expandable mandrel 906 can be minimized. In a preferred embodiment, the operating pressure is reduced in a substantially linear fashion from 100% to about 10% during the end of the extrusion process beginning when the mandrel 906 has completed approximately all but about the last 5 feet of the extrusion process.

In an alternative preferred embodiment, the operating pressure and/or flow rate of the hardenable fluidic sealing material and/or the non hardenable fluidic material are controlled during all phases of the operation of the apparatus 900 to minimize shock.

Alternatively, or in combination, a shock absorber is provided in the support member 904 in order to absorb the shock caused by the sudden release of pressure.

Alternatively, or in combination, a mandrel catching structure is provided above the support member 904 in order to catch or at least decelerate the mandrel 906.

Once the extrusion process is completed, the mandrel 906 is removed from the wellbore. In a preferred embodiment, either before or after the removal of the mandrel 906, the integrity of the fluidic seal of the overlapping joint between the

upper portion of the tubular member 915 and the lower portion of the existing casing is tested using conventional methods. If the fluidic seal of the overlapping joint between the upper portion of the tubular member 915 and the lower portion of the existing casing is satisfactory, then the uncured portion of any of the 5 hardenable fluidic sealing material within the expanded tubular member 915 is then removed in a conventional manner. The hardenable fluidic sealing material within the annular region between the expanded tubular member 915 and the existing casing and new section of wellbore is then allowed to cure.

Preferably any remaining cured hardenable fluidic sealing material within 10 the interior of the expanded tubular members 902 and 915 is then removed in a conventional manner using a conventional drill string. The resulting new section of casing preferably includes the expanded tubular members 902 and 915 and an outer annular layer of cured hardenable fluidic sealing material. The bottom portion of the apparatus 900 comprising the shoe 908 may then be removed by 15 drilling out the shoe 908 using conventional drilling methods.

In an alternative embodiment, during the extrusion process, it may be necessary to remove the entire apparatus 900 from the interior of the wellbore due to a malfunction. In this circumstance, a conventional drill string is used to drill out the interior sections of the apparatus 900 in order to facilitate the removal of 20 the remaining sections. In a preferred embodiment, the interior elements of the apparatus 900 are fabricated from materials such as, for example, cement and aluminum, that permit a conventional drill string to be employed to drill out the interior components.

In particular, in a preferred embodiment, the composition of the interior 25 sections of the mandrel 906 and shoe 908, including one or more of the body of cement 932, the spacer 938, the sealing sleeve 942, the upper cone retainer 944, the lubricator mandrel 946, the lubricator sleeve 948, the guide 950, the housing 954, the body of cement 956, the sealing sleeve 958, and the extension tube 960, are selected to permit at least some of these components to be drilled out using 30 conventional drilling methods and apparatus. In this manner, in the event of a malfunction downhole, the apparatus 900 may be easily removed from the wellbore.

Referring now to Figs. 10a, 10b, 10c, 10d, 10e, 10f, and 10g a method and apparatus for creating a tie-back liner in a wellbore will now be described. As illustrated in Fig. 10a, a wellbore 1000 positioned in a subterranean formation 1002 includes a first casing 1004 and a second casing 1006.

5 The first casing 1004 preferably includes a tubular liner 1008 and a cement annulus 1010. The second casing 1006 preferably includes a tubular liner 1012 and a cement annulus 1014. In a preferred embodiment, the second casing 1006 is formed by expanding a tubular member substantially as described above with reference to Figs. 1-9c or below with reference to Figs. 11a-11f.

10 In a particularly preferred embodiment, an upper portion of the tubular liner 1012 overlaps with a lower portion of the tubular liner 1008. In a particularly preferred embodiment, an outer surface of the upper portion of the tubular liner 1012 includes one or more sealing members 1016 for providing a fluidic seal between the tubular liners 1008 and 1012.

15 Referring to Fig. 10b, in order to create a tie-back liner that extends from the overlap between the first and second casings, 1004 and 1006, an apparatus 1100 is preferably provided that includes an expandable mandrel or pig 1105, a tubular member 1110, a shoe 1115, one or more cup seals 1120, a fluid passage 1130, a fluid passage 1135, one or more fluid passages 1140, seals 1145, and a
20 support member 1150.

The expandable mandrel or pig 1105 is coupled to and supported by the support member 1150. The expandable mandrel 1105 is preferably adapted to controllably expand in a radial direction. The expandable mandrel 1105 may comprise any number of conventional commercially available expandable mandrels
25 modified in accordance with the teachings of the present disclosure. In a preferred embodiment, the expandable mandrel 1105 comprises a hydraulic expansion tool substantially as disclosed in U.S. Pat. No. 5,348,095, the disclosure of which is incorporated herein by reference, modified in accordance with the teachings of the present disclosure.

30 The tubular member 1110 is coupled to and supported by the expandable mandrel 1105. The tubular member 1110 is expanded in the radial direction and extruded off of the expandable mandrel 1105. The tubular member 1110 may be

fabricated from any number of materials such as, for example, Oilfield Country Tubular Goods, 13 chromium tubing or plastic piping. In a preferred embodiment, the tubular member 1110 is fabricated from Oilfield Country Tubular Goods.

The inner and outer diameters of the tubular member 1110 may range, for example, from approximately 1.905 to 119.38 cms (0.75 to 47 inches) and 2.667 to 121.92 cms (1.05 to 48 inches), respectively. In a preferred embodiment, the inner and outer diameters of the tubular member 1110 range from about 7.62 to 39.37 cms (3 to 15.5 inches) and 8.89 to 40.64 cms (3.5 to 16 inches), respectively in order to optimally provide coverage for typical oilfield casing sizes. The tubular member 1110 preferably comprises a solid member.

In a preferred embodiment, the upper end portion of the tubular member 1110 is slotted, perforated, or otherwise modified to catch or slow down the mandrel 1105 when it completes the extrusion of tubular member 1110. In a preferred embodiment, the length of the tubular member 1110 is limited to minimize the possibility of buckling. For typical tubular member 1110 materials, the length of the tubular member 1110 is preferably limited to between about 12.192 to 6096m (40 to 20,000 feet) in length.

The shoe 1115 is coupled to the expandable mandrel 1105 and the tubular member 1110. The shoe 1115 includes the fluid passage 1135. The shoe 1115 may comprise any number of conventional commercially available shoes such as, for example, Super Seal II float shoe, Super Seal II Down-Jet float shoe or a guide shoe with a sealing sleeve for a latch down plug modified in accordance with the teachings of the present disclosure. In a preferred embodiment, the shoe 1115 comprises an aluminum down-jet guide shoe with a sealing sleeve for a latch-down plug with side ports radiating off of the exit flow port available from Halliburton Energy Services in Dallas, TX, modified in accordance with the teachings of the present disclosure, in order to optimally guide the tubular member 1100 to the overlap between the tubular member 1100 and the casing 1012, optimally fluidically isolate the interior of the tubular member 1100 after the latch down plug has seated, and optimally permit drilling out of the shoe 1115 after completion of the expansion and cementing operations.

In a preferred embodiment, the shoe 1115 includes one or more side outlet ports 1140 in fluidic communication with the fluid passage 1135. In this manner,

the shoe 1115 injects hardenable fluidic sealing material into the region outside the shoe 1115 and tubular member 1110. In a preferred embodiment, the shoe 1115 includes one or more of the fluid passages 1140 each having an inlet geometry that can receive a dart and/or a ball sealing member. In this manner, the fluid passages
5 1140 can be sealed off by introducing a plug, dart and/or ball sealing elements into the fluid passage 1130.

The cup seal 1120 is coupled to and supported by the support member 1150. The cup seal 1120 prevents foreign materials from entering the interior region of the tubular member 1110 adjacent to the expandable mandrel 1105. The cup seal
10 1120 may comprise any number of conventional commercially available cup seals such as, for example, TP cups or Selective Injection Packer (SIP) cups modified in accordance with the teachings of the present disclosure. In a preferred embodiment, the cup seal 1120 comprises a SIP cup, available from Halliburton Energy Services in Dallas, TX in order to optimally provide a barrier to debris and
15 contain a body of lubricant.

The fluid passage 1130 permits fluidic materials to be transported to and from the interior region of the tubular member 1110 below the expandable mandrel 1105. The fluid passage 1130 is coupled to and positioned within the support member 1150 and the expandable mandrel 1105. The fluid passage 1130
20 preferably extends from a position adjacent to the surface to the bottom of the expandable mandrel 1105. The fluid passage 1130 is preferably positioned along a centerline of the apparatus 1100. The fluid passage 1130 is preferably selected to transport materials such as cement, drilling mud or epoxies at flow rates and pressures ranging from about 0 to 11356.2355 litres/minute (0 to 3,000 gallons/minute)
25 and 0 to 620.52813 bar (0 to 9,000 psi) in order to optimally provide sufficient operating pressures to circulate fluids at operational efficient rates.

The fluid passage 1135 permits fluidic materials to be transmitted from fluid passage 1130 to the interior of the tubular member 1110 below the mandrel 1105.

The fluid passages 1140 permits fluidic materials to be transported to and
30 from the region exterior to the tubular member 1110 and shoe 1115. The fluid passages 1140 are coupled to and positioned within the shoe 1115 in fluidic communication with the interior region of the tubular member 1110 below the

expandable mandrel 1105. The fluid passages 1140 preferably have a cross-sectional shape that permits a plug, or other similar device, to be placed in the fluid passages 1140 to thereby block further passage of fluidic materials. In this manner, the interior region of the tubular member 1110 below the expandable
5 mandrel 1105 can be fluidically isolated from the region exterior to the tubular member 1105. This permits the interior region of the tubular member 1110 below the expandable mandrel 1105 to be pressurized.

The fluid passages 1140 are preferably positioned along the periphery of the shoe 1115. The fluid passages 1140 are preferably selected to convey materials
10 such as cement, drilling mud or epoxies at flow rates and pressures ranging from about 0 to 11356.2355 litres/minute (0 to 3,000 gallons/minute) and 0 to 62.52813 bar (0 to 9,000 psi) in order to optimally fill the annular region between the tubular member 1110 and the tubular liner 1008 with fluidic materials. In a preferred embodiment, the fluid passages 1140 include an inlet geometry that can receive a dart and/or a ball sealing member. In this manner, the fluid passages 1140 can be sealed off by introducing a plug,
15 dart and/or ball sealing elements into the fluid passage 1130. In a preferred embodiment, the apparatus 1100 includes a plurality of fluid passage 1140.

In an alternative embodiment, the base of the shoe 1115 includes a single inlet passage coupled to the fluid passages 1140 that is adapted to receive a plug,
20 or other similar device, to permit the interior region of the tubular member 1110 to be fluidically isolated from the exterior of the tubular member 1110.

The seals 1145 are coupled to and supported by a lower end portion of the tubular member 1110. The seals 1145 are further positioned on an outer surface of the lower end portion of the tubular member 1110. The seals 1145 permit the
25 overlapping joint between the upper end portion of the casing 1012 and the lower end portion of the tubular member 1110 to be fluidically sealed.

The seals 1145 may comprise any number of conventional commercially available seals such as, for example, lead, rubber, Teflon™ or epoxy seals modified in accordance with the teachings of the present disclosure. In a preferred
30 embodiment, the seals 1145 comprise seals molded from Stratalock epoxy available from Halliburton Energy Services in Dallas, TX in order to optimally provide a

hydraulic seal in the overlapping joint and optimally provide load carrying capacity to withstand the range of typical tensile and compressive loads.

In a preferred embodiment, the seals 1145 are selected to optimally provide a sufficient frictional force to support the expanded tubular member 1110 from the tubular liner 1008. In a preferred embodiment, the frictional force provided by the seals 1145 ranges from about 68.94757 to 68,947.57 bar (1,000 to 1,000,000 lbf) in tension and compression in order to optimally support the expanded tubular member 1110.

The support member 1150 is coupled to the expandable mandrel 1105, tubular member 1110, shoe 1115, and seal 1120. The support member 1150 preferably comprises an annular member having sufficient strength to carry the apparatus 1100 into the wellbore 1000. In a preferred embodiment, the support member 1150 further includes one or more conventional centralizers (not illustrated) to help stabilize the tubular member 1110.

In a preferred embodiment, a quantity of lubricant 1150 is provided in the annular region above the expandable mandrel 1105 within the interior of the tubular member 1110. In this manner, the extrusion of the tubular member 1110 off of the expandable mandrel 1105 is facilitated. The lubricant 1150 may comprise any number of conventional commercially available lubricants such as, for example Lubriplate™, chlorine based lubricants or Climax 1500 Antiseize (3100). In a preferred embodiment, the lubricant 1150 comprises Climax 1500 Antiseize (3100) available from Climax Lubricants and Equipment Co. in Houston, TX in order to optimally provide lubrication for the extrusion process.

In a preferred embodiment, the support member 1150 is thoroughly cleaned prior to assembly to the remaining portions of the apparatus 1100. In this manner, the introduction of foreign material into the apparatus 1100 is minimized. This minimizes the possibility of foreign material clogging the various flow passages and valves of the apparatus 1100 and to ensure that no foreign material interferes with the expansion mandrel 1105 during the extrusion process.

In a particularly preferred embodiment, the apparatus 1100 includes a packer 1155 coupled to the bottom section of the shoe 1115 for fluidically isolating the region of the wellbore 1000 below the apparatus 1100. In this manner, fluidic materials are prevented from entering the region of the wellbore 1000 below the

apparatus 1100. The packer 1155 may comprise any number of conventional commercially available packers such as, for example, EZ Drill Packer, EZ SV Packer or a drillable cement retainer. In a preferred embodiment, the packer 1155 comprises an EZ Drill Packer available from Halliburton Energy Services in
5 Dallas, TX. In an alternative embodiment, a high gel strength pill may be set below the tie-back in place of the packer 1155. In another alternative embodiment, the packer 1155 may be omitted.

In a preferred embodiment, before or after positioning the apparatus 1100 within the wellbore 1100, a couple of wellbore volumes are circulated in order to
10 ensure that no foreign materials are located within the wellbore 1000 that might clog up the various flow passages and valves of the apparatus 1100 and to ensure that no foreign material interferes with the operation of the expansion mandrel 1105.

As illustrated in Fig. 10c, a hardenable fluidic sealing material 1160 is then
15 pumped from a surface location into the fluid passage 1130. The material 1160 then passes from the fluid passage 1130 into the interior region of the tubular member 1110 below the expandable mandrel 1105. The material 1160 then passes from the interior region of the tubular member 1110 into the fluid passages 1140. The material 1160 then exits the apparatus 1100 and fills the annular region
20 between the exterior of the tubular member 1110 and the interior wall of the tubular liner 1008. Continued pumping of the material 1160 causes the material 1160 to fill up at least a portion of the annular region.

The material 1160 may be pumped into the annular region at pressures and flow rates ranging, for example, from about 0 to 344.73785 bar (0 to 5,000 psi) and 0 to 5678.1177
25 litres/minute (0 to 1,500 gallons/min), respectively. In a preferred embodiment, the material 1160 is pumped into the annular region at pressures and flow rates specifically designed for the casing sizes being run, the annular spaces being filled, the pumping equipment available, and the properties of the fluid being pumped. The optimum flow rates and pressures are preferably calculated using conventional empirical methods.

30 The hardenable fluidic sealing material 1160 may comprise any number of conventional commercially available hardenable fluidic sealing materials such as, for example, slag mix, cement or epoxy. In a preferred embodiment, the

hardenable fluidic sealing material 1160 comprises blended cements specifically designed for well section being tied-back, available from Halliburton Energy Services in Dallas, TX in order to optimally provide proper support for the tubular member 1110 while maintaining optimum flow characteristics so as to minimize
5 operational difficulties during the displacement of cement in the annular region. The optimum blend of the blended cements are preferably determined using conventional empirical methods.

The annular region may be filled with the material 1160 in sufficient quantities to ensure that, upon radial expansion of the tubular member 1110, the
10 annular region will be filled with material 1160.

As illustrated in Fig. 10d, once the annular region has been adequately filled with material 1160, one or more plugs 1165, or other similar devices, preferably are introduced into the fluid passages 1140 thereby fluidically isolating the interior region of the tubular member 1110 from the annular region external to the tubular
15 member 1110. In a preferred embodiment, a non hardenable fluidic material 1161 is then pumped into the interior region of the tubular member 1110 below the mandrel 1105 causing the interior region to pressurize. In a particularly preferred embodiment, the one or more plugs 1165, or other similar devices, are introduced into the fluid passage 1140 with the introduction of the non hardenable fluidic
20 material. In this manner, the amount of hardenable fluidic material within the interior of the tubular member 1110 is minimized.

As illustrated in Fig. 10e, once the interior region becomes sufficiently pressurized, the tubular member 1110 is extruded off of the expandable mandrel 1105. During the extrusion process, the expandable mandrel 1105 is raised out of
25 the expanded portion of the tubular member 1110.

The plugs 1165 are preferably placed into the fluid passages 1140 by introducing the plugs 1165 into the fluid passage 1130 at a surface location in a conventional manner. The plugs 1165 may comprise any number of conventional commercially available devices from plugging a fluid passage such as, for example,
30 brass balls, plugs, rubber balls, or darts modified in accordance with the teachings of the present disclosure.

In a preferred embodiment, the plugs 1165 comprise low density rubber balls. In an alternative embodiment, for a shoe 1105 having a common central inlet passage, the plugs 1165 comprise a single latch down dart.

After placement of the plugs 1165 in the fluid passages 1140, the non hardenable fluidic material
5 1161 is preferably pumped into the interior region of the tubular member 1110 below the mandrel 1105 at pressures and flow rates ranging from approximately 34.473 to 620.52813 bar (500 to 9,000 psi) and 151.4164 to 113, 562.355 litres/minute (40 to 30,000 gallons/min). In a preferred embodiment, after placement of the plugs 1165 in the fluid passages 1140, the non hardenable fluidic material 1161 is preferably pumped into the interior region of the tubular member 1110 below the mandrel 1105 at pressures and flow rates ranging from approximately 82.737 to 586.0543 bar (1200 to 8500 psi) and
10 151.4164 to 4731.7648 litres/minute (40 to 1250 gallons/min) in order to optimally provide extrusion of typical tubulars.

For typical tubular members 1110, the extrusion of the tubular member 1110 off of the expandable mandrel 1105 will begin when the pressure of the interior region of the tubular member 1110 below the mandrel 1105 reaches, for example, approximately
15 82.737 to 586.0543 bar (1200 to 8500 psi). In a preferred embodiment, the extrusion of the tubular member 1110 off of the expandable mandrel 1105 begins when the pressure of the interior region of the tubular member 1110 below the mandrel 1105 reaches approximately 82.737 to 586.0543 bar (1200 to 8500 psi).

During the extrusion process, the expandable mandrel 1105 may be raised out of the expanded portion of the tubular member 1110 at rates ranging, for example, from
20 about 0 to 1.524 m/s (0 to 5 ft/sec). In a preferred embodiment, during the extrusion process, the expandable mandrel 1105 is raised out of the expanded portion of the tubular member 1110 at rates ranging from about 0 to 0.6096 m/s (0 to 2 ft/sec) in order to optimally provide permit adjustment of operational parameters, and optimally ensure that the extrusion process will be completed before the material 1160 cures.

25

In a preferred embodiment, at least a portion 1180 of the tubular member 1110 has an internal diameter less than the outside diameter of the mandrel 1105. In this manner, when the mandrel 1105 expands the section 1180 of the tubular
30 member 1110, at least a portion of the expanded section 1180 effects a seal with at least the wellbore casing 1012. In a particularly preferred embodiment, the seal is effected by c mpressing the seals 1016 between the expanded section 1180 and

the wellbore casing 1012. In a preferred embodiment, the contact pressure of the joint between the expanded section 1180 of the tubular member 1110 and the casing 1012 ranges from about 34.473785 to 689.6757 bar (500 to 10,000 psi) in order to optimally provide pressure to activate the sealing members 1145 and provide optimal resistance to ensure that the joint will withstand typical extremes of tensile and compressive loads.

In an alternative preferred embodiment, substantially all of the entire length of the tubular member 1110 has an internal diameter less than the outside diameter of the mandrel 1105. In this manner, extrusion of the tubular member 1110 by the mandrel 1105 results in contact between substantially all of the expanded tubular member 1110 and the existing casing 1008. In a preferred embodiment, the contact pressure of the joint between the expanded tubular member 1110 and the casings 1008 and 1012 ranges from about 34.473785 to 689.6757 bar (500 to 10,000 psi) in order to optimally provide pressure to activate the sealing members 1145 and provide optimal resistance to ensure that the joint will withstand typical extremes of tensile and compressive loads.

In a preferred embodiment, the operating pressure and flow rate of the material 1161 is controllably ramped down when the expandable mandrel 1105 reaches the upper end portion of the tubular member 1110. In this manner, the sudden release of pressure caused by the complete extrusion of the tubular member 1110 off of the expandable mandrel 1105 can be minimized. In a preferred embodiment, the operating pressure of the fluidic material 1161 is reduced in a substantially linear fashion from 100% to about 10% during the end of the extrusion process beginning when the mandrel 1105 has completed approximately all but about 1.524m (5 feet) of the extrusion process.

Alternatively, or in combination, a shock absorber is provided in the support member 1150 in order to absorb the shock caused by the sudden release of pressure.

Alternatively, or in combination, a mandrel catching structure is provided in the upper end portion of the tubular member 1110 in order to catch or at least decelerate the mandrel 1105.

Referring to Fig. 10f, once the extrusion process is completed, the expandable mandrel 1105 is removed from the wellbore 1000. In a preferred embodiment, either before or after the removal of the expandable mandrel 1105, the integrity of the fluidic seal of the joint between the upper portion of the tubular member 1110 and the upper portion of the tubular liner 1108 is tested using conventional methods. If the fluidic seal of the joint between the upper portion of the tubular member 1110 and the upper portion of the tubular liner 1008 is satisfactory, then the uncured portion of the material 1160 within the expanded tubular member 1110 is then removed in a conventional manner. The material 1160 within the annular region between the tubular member 1110 and the tubular liner 1008 is then allowed to cure.

As illustrated in Fig. 10f, preferably any remaining cured material 1160 within the interior of the expanded tubular member 1110 is then removed in a conventional manner using a conventional drill string. The resulting tie-back liner of casing 1170 includes the expanded tubular member 1110 and an outer annular layer 1175 of cured material 1160.

As illustrated in Fig. 10g, the remaining bottom portion of the apparatus 1100 comprising the shoe 1115 and packer 1155 is then preferably removed by drilling out the shoe 1115 and packer 1155 using conventional drilling methods.

In a particularly preferred embodiment, the apparatus 1100 incorporates the apparatus 900.

Referring now to Figs. 11a-11f, an embodiment of an apparatus and method for hanging a tubular liner off of an existing wellbore casing will now be described. As illustrated in Fig. 11a, a wellbore 1200 is positioned in a subterranean formation 1205. The wellbore 1200 includes an existing cased section 1210 having a tubular casing 1215 and an annular outer layer of cement 1220.

In order to extend the wellbore 1200 into the subterranean formation 1205, a drill string 1225 is used in a well known manner to drill out material from the subterranean formation 1205 to form a new section 1230.

As illustrated in Fig. 11b, an apparatus 1300 for forming a wellbore casing in a subterranean formation is then positioned in the new section 1230 of the wellbore 100. The apparatus 1300 preferably includes an expandable mandrel or

5 pig 1305, a tubular member 1310, a shoe 1315, a fluid passage 1320, a fluid passage 1330, a fluid passage 1335, seals 1340, a support member 1345, and a wiper plug 1350.

The expandable mandrel 1305 is coupled to and supported by the support member 1345. The expandable mandrel 1305 is preferably adapted to controllably expand in a radial direction. The expandable mandrel 1305 may comprise any number of conventional commercially available expandable mandrels modified in accordance with the teachings of the present disclosure. In a preferred embodiment, the expandable mandrel 1305 comprises a hydraulic expansion tool 10 substantially as disclosed in U.S. Pat. No. 5,348,095, the disclosure of which is incorporated herein by reference, modified in accordance with the teachings of the present disclosure.

The tubular member 1310 is coupled to and supported by the expandable mandrel 1305. The tubular member 1310 is preferably expanded in the radial 15 direction and extruded off of the expandable mandrel 1305. The tubular member 1310 may be fabricated from any number of materials such as, for example, Oilfield Country Tubular Goods (OCTG), 13 chromium steel tubing/casing or plastic casing. In a preferred embodiment, the tubular member 1310 is fabricated from OCTG. The inner and outer diameters of the tubular member 1310 may range, for 20 example, from approximately 1.905 to 119.38 cms (0.75 to 47 inches) and 2.667 to 121.92 cms (1.05 to 48 inches), respectively. In a preferred embodiment, the inner and outer diameters of the tubular member 1310 range from about 7.62 to 39.37 cms (3 to 15.5 inches) and 8.89 to 40.64 cms (3.5 to 16 inches), respectively in order to optimally provide minimal telescoping effect in the most commonly encountered wellbore sizes.

25 In a preferred embodiment, the tubular member 1310 includes an upper portion 1355, an intermediate portion 1360, and a lower portion 1365. In a preferred embodiment, the wall thickness and outer diameter of the upper portion 1355 of the tubular member 1310 range from about 0.375 to 3.81 cms (3/8 to 1 1/2 inches) and 8.89 to 40.64 cms (3 1/2 to 16 inches), respectively. In a preferred embodiment, the wall thickness and outer diameter of 30 the intermediate portion 1360 of the tubular member 1310 range from about 1.5825 to 1.905 cms (0.625 to 0.75 inches) and 7.62 to 48.26 cms (3 to 19 inches), respectively. In a preferred embodiment, the wall thickness and outer diameter of the lower portion 1365 f

the tubular member 1310 rang from about 0.375 to 3.81 cms (3/8 to 1.5 inches) and 8.89 to 40.64 cms (3.5 to 16 inches), respectively.

In a particularly preferred embodiment, the wall thickness of the intermediate section 1360 of the tubular member 1310 is less than or equal to the wall thickness of the upper and lower sections, 1355 and 1365, of the tubular member 1310 in order to optimally facilitate the initiation of the extrusion process and optimally permit the placement of the apparatus in areas of the wellbore having tight clearances.

The tubular member 1310 preferably comprises a solid member. In a preferred embodiment, the upper end portion 1355 of the tubular member 1310 is slotted, perforated, or otherwise modified to catch or slow down the mandrel 1305 when it completes the extrusion of tubular member 1310. In a preferred embodiment, the length of the tubular member 1310 is limited to minimize the possibility of buckling. For typical tubular member 1310 materials, the length of the tubular member 1310 is preferably limited to between about 12.192 to 6096 m (40 to 20,000 feet) in length.

The shoe 1315 is coupled to the tubular member 1310. The shoe 1315 preferably includes fluid passages 1330 and 1335. The shoe 1315 may comprise any number of conventional commercially available shoes such as, for example, Super Seal II float shoe, Super Seal II Down-Jet float shoe or guide shoe with a sealing sleeve for a latch-down plug modified in accordance with the teachings of the present disclosure. In a preferred embodiment, the shoe 1315 comprises an aluminum down-jet guide shoe with a sealing sleeve for a latch-down plug available from Halliburton Energy Services in Dallas, TX, modified in accordance with the teachings of the present disclosure, in order to optimally guide the tubular member 1310 into the wellbore 1200, optimally fluidicly isolate the interior of the tubular member 1310, and optimally permit the complete drill out of the shoe 1315 upon the completion of the extrusion and cementing operations.

In a preferred embodiment, the shoe 1315 further includes one or more side outlet ports in fluidic communication with the fluid passage 1330. In this manner, the shoe 1315 preferably injects hardenable fluidic sealing material into the region outside the shoe 1315 and tubular member 1310. In a preferred embodiment, the

shoe 1315 includes the fluid passage 1330 having an inlet geometry that can receive a fluidic sealing member. In this manner, the fluid passage 1330 can be sealed off by introducing a plug, dart and/or ball sealing elements into the fluid passage 1330.

5 The fluid passage 1320 permits fluidic materials to be transported to and from the interior region of the tubular member 1310 below the expandable mandrel 1305. The fluid passage 1320 is coupled to and positioned within the support member 1345 and the expandable mandrel 1305. The fluid passage 1320 preferably extends from a position adjacent to the surface to the bottom of the
10 expandable mandrel 1305. The fluid passage 1320 is preferably positioned along a centerline of the apparatus 1300. The fluid passage 1320 is preferably selected to transport materials such as cement, drilling mud, or epoxies at flow rates and pressures ranging from about 0 to 11356.2355 litres/minute (0 to 3,000 gallons/minute) and 0 to 620.52813 bar (0 to 9,000 psi) in order to optimally provide sufficient operating
15 pressures to circulate fluids at operationally efficient rates.

The fluid passage 1330 permits fluidic materials to be transported to and from the region exterior to the tubular member 1310 and shoe 1315. The fluid passage 1330 is coupled to and positioned within the shoe 1315 in fluidic communication with the interior region 1370 of the tubular member 1310 below
20 the expandable mandrel 1305. The fluid passage 1330 preferably has a cross-sectional shape that permits a plug, or other similar device, to be placed in fluid passage 1330 to thereby block further passage of fluidic materials. In this manner, the interior region 1370 of the tubular member 1310 below the expandable mandrel 1305 can be fluidically isolated from the region exterior to the tubular
25 member 1310. This permits the interior region 1370 of the tubular member 1310 below the expandable mandrel 1305 to be pressurized. The fluid passage 1330 is preferably positioned substantially along the centerline of the apparatus 1300.

The fluid passage 1330 is preferably selected to convey materials such as cement, drilling mud or epoxies at flow rates and pressures ranging from about 0 to 11356.2355
30 litres/minute (0 to 3,000 gallons/minute) and 0 to 620.52813 bar (0 to 9,000 psi) in order to optimally fill the annular region between the tubular member 1310 and the new section 1230 of the wellbore 1200 with fluidic materials. In a preferred embodiment, the fluid passage 1330

includes an inlet geometry that can receive a dart and/or a ball sealing member. In this manner, the fluid passage 1330 can be sealed off by introducing a plug, dart and/or ball sealing elements into the fluid passage 1320.

The fluid passage 1335 permits fluidic materials to be transported to and from the region exterior to the tubular member 1310 and shoe 1315. The fluid passage 1335 is coupled to and positioned within the shoe 1315 in fluidic communication with the fluid passage 1330. The fluid passage 1335 is preferably positioned substantially along the centerline of the apparatus 1300. The fluid passage 1335 is preferably selected to convey materials such as cement, drilling mud or epoxies at flow rates and pressures ranging from about 0 to 11356.2355 litres/minute (0 to 3,000 gallons/minute) and 0 to 620.52813 bar (0 to 9,000 psi) in order to optimally fill the annular region between the tubular member 1310 and the new section 1230 of the wellbore 1200 with fluidic materials.

The seals 1340 are coupled to and supported by the upper end portion 1355 of the tubular member 1310. The seals 1340 are further positioned on an outer surface of the upper end portion 1355 of the tubular member 1310. The seals 1340 permit the overlapping joint between the lower end portion of the casing 1215 and the upper portion 1355 of the tubular member 1310 to be fluidically sealed. The seals 1340 may comprise any number of conventional commercially available seals such as, for example, lead, rubber, Teflon™, or epoxy seals modified in accordance with the teachings of the present disclosure. In a preferred embodiment, the seals 1340 comprise seals molded from Stratalock epoxy available from Halliburton Energy Services in Dallas, TX in order to optimally provide a hydraulic seal in the annulus of the overlapping joint while also creating optimal load bearing capability to withstand typical tensile and compressive loads.

In a preferred embodiment, the seals 1340 are selected to optimally provide a sufficient frictional force to support the expanded tubular member 1310 from the existing casing 1215. In a preferred embodiment, the frictional force provided by the seals 1340 ranges from about 68.94757 to 68,947.57 bar (1,000 to 1,000,000 lbf) in order to optimally support the expanded tubular member 1310.

The support member 1345 is coupled to the expandable mandrel 1305, tubular member 1310, shoe 1315, and seals 1340. The support member 1345

preferably comprises an annular member having sufficient strength to carry the apparatus 1300 into the new section 1230 of the wellbore 1200. In a preferred embodiment, the support member 1345 further includes one or more conventional centralizers (not illustrated) to help stabilize the tubular member 1310.

5 In a preferred embodiment, the support member 1345 is thoroughly cleaned prior to assembly to the remaining portions of the apparatus 1300. In this manner, the introduction of foreign material into the apparatus 1300 is minimized. This minimizes the possibility of foreign material clogging the various flow passages and valves of the apparatus 1300 and to ensure that no foreign material
10 interferes with the expansion process.

The wiper plug 1350 is coupled to the mandrel 1305 within the interior region 1370 of the tubular member 1310. The wiper plug 1350 includes a fluid passage 1375 that is coupled to the fluid passage 1320. The wiper plug 1350 may
15 comprise one or more conventional commercially available wiper plugs such as, for example, Multiple Stage Cementer latch-down plugs, Omega latch-down plugs or three-wiper latch-down plug modified in accordance with the teachings of the present disclosure. In a preferred embodiment, the wiper plug 1350 comprises a Multiple Stage Cementer latch-down plug available from Halliburton Energy Services in Dallas, TX modified in a conventional manner for releasable
20 attachment to the expansion mandrel 1305.

In a preferred embodiment, before or after positioning the apparatus 1300 within the new section 1230 of the wellbore 1200, a couple of wellbore volumes are circulated in order to ensure that no foreign materials are located within the wellbore 1200 that might clog up the various flow passages and valves of the
25 apparatus 1300 and to ensure that no foreign material interferes with the extrusion process.

As illustrated in Fig. 11c, a hardenable fluidic sealing material 1380 is then pumped from a surface location into the fluid passage 1320. The material 1380 then passes from the fluid passage 1320, through the fluid passage 1375, and into
30 the interior region 1370 of the tubular member 1310 below the expandable mandrel 1305. The material 1380 then passes from the interior region 1370 into the fluid passage 1330. The material 1380 then exits the apparatus 1300 via the

fluid passage 1335 and fills the annular region 1390 between the exterior of the tubular member 1310 and the interior wall of the new section 1230 of the wellbore 1200. Continued pumping of the material 1380 causes the material 1380 to fill up at least a portion of the annular region 1390.

5 The material 1380 may be pumped into the annular region 1390 at pressures and flow rates ranging, for example, from about 0 to 344.73785 bar (0 to 5000 psi) and 0 to 5678.1177 litres/minute (0 to 1,500 gallons/min), respectively. In a preferred embodiment, the material 1380 is pumped into the annular region 1390 at pressures and flow rates ranging from about 0 to 344.73785 bar (0 to 5000 psi) and 0 to 5678.1177 litres/minute (0 to 1,500 gallons/min), respectively, in order to optimally fill the annular region between the tubular member 1310 and
10 the new section 1230 of the wellbore 1200 with the hardenable fluidic sealing material 1380.

The hardenable fluidic sealing material 1380 may comprise any number of conventional commercially available hardenable fluidic sealing materials such as, for example, slag mix, cement or epoxy. In a preferred embodiment, the
15 hardenable fluidic sealing material 1380 comprises blended cements designed specifically for the well section being drilled and available from Halliburton Energy Services in order to optimally provide support for the tubular member 1310 during displacement of the material 1380 in the annular region 1390. The optimum blend of the cement is preferably determined using conventional empirical methods.

20 The annular region 1390 preferably is filled with the material 1380 in sufficient quantities to ensure that, upon radial expansion of the tubular member 1310, the annular region 1390 of the new section 1230 of the wellbore 1200 will be filled with material 1380.

As illustrated in Fig. 11d, once the annular region 1390 has been adequately
25 filled with material 1380, a wiper dart 1395, or other similar device, is introduced into the fluid passage 1320. The wiper dart 1395 is preferably pumped through the fluid passage 1320 by a non hardenable fluidic material 1381. The wiper dart 1395 then preferably engages the wiper plug 1350.

As illustrated in Fig. 11e, in a preferred embodiment, engagement of the
30 wiper dart 1395 with the wiper plug 1350 causes the wiper plug 1350 to decouple from the mandrel 1305. The wiper dart 1395 and wiper plug 1350 then preferably will lodge in the fluid passage 1330, thereby blocking fluid flow through the fluid

passage 1330, and fluidically isolating the interior region 1370 of the tubular member 1310 from the annular region 1390. In a preferred embodiment, the non hardenable fluidic material 1381 is then pumped into the interior region 1370 causing the interior region 1370 to pressurize. Once the interior region 1370 becomes sufficiently pressurized, the tubular member 1310 is extruded off of the expandable mandrel 1305. During the extrusion process, the expandable mandrel 1305 is raised out of the expanded portion of the tubular member 1310 by the support member 1345.

The wiper dart 1395 is preferably placed into the fluid passage 1320 by introducing the wiper dart 1395 into the fluid passage 1320 at a surface location in a conventional manner. The wiper dart 1395 may comprise any number of conventional commercially available devices from plugging a fluid passage such as, for example, Multiple Stage Cementer latch-down plugs, Omega latch-down plugs or three wiper latch-down plug/dart modified in accordance with the teachings of the present disclosure. In a preferred embodiment, the wiper dart 1395 comprises a three wiper latch-down plug modified to latch and seal in the Multiple Stage Cementer latch down plug 1350. The three wiper latch-down plug is available from Halliburton Energy Services in Dallas, TX.

After blocking the fluid passage 1330 using the wiper plug 1330 and wiper dart 1395, the non hardenable fluidic material 1381 may be pumped into the interior region 1370 at pressures and flow rates ranging, for example, from approximately 0 to 344.73785 bar (0 to 5000 psi) and 0 to 5678.1177 litres/minute (0 to 1500 gallons/min) in order to optimally extrude the tubular member 1310 off of the mandrel 1305. In this manner, the amount of hardenable fluidic material within the interior of the tubular member 1310 is minimized.

In a preferred embodiment, after blocking the fluid passage 1330, the non hardenable fluidic material 1381 is preferably pumped into the interior region 1370 at pressures and flow rates ranging from approximately 34.473 to 620.52813 bar (500 to 9,000 psi) and 151.4164 to 11356.2355 litres/minute (40 to 3,000 gallons/min) in order to optimally provide operating pressures to maintain the expansion process at rates sufficient to permit adjustments to be made in operating parameters during the extrusion process.

For typical tubular members 1310, the extrusion of the tubular member 1310 off of the expandable mandrel 1305 will begin when the pressure of the interior region 1370 reaches, for example, approximately 34.473 to 620.52813 bar (500 to 9,000 psi). In a preferred embodiment, the extrusion of the tubular member 1310 off of the expandable mandrel 1305 is a function of the tubular member diameter, wall thickness of the tubular member, geometry of the mandrel, the type of lubricant, the composition of the shoe and tubular member, and the yield strength of the tubular member. The optimum flow rate and operating pressures are preferably determined using conventional empirical methods.

10 During the extrusion process, the expandable mandrel 1305 may be raised out of the expanded portion of the tubular member 1310 at rates ranging, for example, from about 0 to 1.524 m/s (0 to 5 ft/sec). In a preferred embodiment, during the extrusion process, the expandable mandrel 1305 may be raised out of the expanded portion of the tubular member 1310 at rates ranging from about 0 to 0.6096 m (0 to 2 ft/sec) in order to optimally provide an efficient process, optimally permit operator
15 adjustment of operation parameters, and ensure optimal completion of the extrusion process before curing of the material 1380.

When the upper end portion 1355 of the tubular member 1310 is extruded off of the expandable mandrel 1305, the outer surface of the upper end portion 1355 of the tubular member 1310 will preferably contact the interior surface of the lower end portion
20 of the casing 1215 to form an fluid tight overlapping joint. the contact pressure of the overlapping joint may range, for example, from approximately 3.447379 to 1,278.9514 bar (50 to 20,000 psi). In a preferred embodiment, the contact pressure of the overlapping joint ranges from approximately 27.579028 to 689.4757 bar (400 to 10,000 psi) in order to optimally provide contact pressure sufficient to ensure annular sealing and provide enough resistance to withstand typical tensile and compressive loads. In a
25 particularly preferred embodiment, the sealing members 1340 will ensure an adequate fluidic and gaseous seal in the overlapping joint.

In a preferred embodiment, the operating pressure and flow rate of the non hardenable fluidic material 1381 is controllably ramped down when the expandable mandrel 1305 reaches the upper end portion 1355 of the tubular member 1310. In this
30 manner, the sudden release of pressure caused by the complete extrusion

of the tubular member 1310 off of the expandable mandrel 1305 can be minimized. In a preferred embodiment, the operating pressure is reduced in a substantially linear fashion from 100% to about 10% during the end of the extrusion process beginning when the mandrel 1305 has completed approximately all but about 5 feet of the extrusion process.

Alternatively, or in combination, a shock absorber is provided in the support member 1345 in order to absorb the shock caused by the sudden release of pressure.

Alternatively, or in combination, a mandrel catching structure is provided in the upper end portion 1355 of the tubular member 1310 in order to catch or at least decelerate the mandrel 1305.

Once the extrusion process is completed, the expandable mandrel 1305 is removed from the wellbore 1200. In a preferred embodiment, either before or after the removal of the expandable mandrel 1305, the integrity of the fluidic seal of the overlapping joint between the upper portion 1355 of the tubular member 1310 and the lower portion of the casing 1215 is tested using conventional methods. If the fluidic seal of the overlapping joint between the upper portion 1355 of the tubular member 1310 and the lower portion of the casing 1215 is satisfactory, then the uncured portion of the material 1380 within the expanded tubular member 1310 is then removed in a conventional manner. The material 1380 within the annular region 1390 is then allowed to cure.

As illustrated in Fig. 11f, preferably any remaining cured material 1380 within the interior of the expanded tubular member 1310 is then removed in a conventional manner using a conventional drill string. The resulting new section of casing 1400 includes the expanded tubular member 1310 and an outer annular layer 1405 of cured material 305. The bottom portion of the apparatus 1300 comprising the shoe 1315 may then be removed by drilling out the shoe 1315 using conventional drilling methods.

A method of creating a casing in a borehole located in a subterranean formation has been described that includes installing a tubular liner and a mandrel in the borehole. A body of fluidic material is then injected into the borehole. The tubular liner is then radially expanded by extruding the liner off of the mandrel.

The injecting preferably includes injecting a hardenable fluidic sealing material into an annular region located between the borehole and the exterior of the tubular liner; and a non hardenable fluidic material into an interior region of the tubular liner below the mandrel. The method preferably includes fluidically isolating the annular region from the interior region before injecting the second quantity of the non hardenable sealing material into the interior region. The injecting the hardenable fluidic sealing material is preferably provided at operating pressures and flow rates ranging from about 0 to 344.73785 bar (0 to 5000 psi) and 0 to 567.1177 litres/minute (0 to 1,500 gallons/min). The injecting of the non hardenable fluidic material is preferably provided at operating pressures and flow rates ranging from about 34.473 to 620.52813 bar (500 to 9000 psi) and 151.4164 to 11356.2355 litres/minute (40 to 3,000 gallons/min). The injecting of the non hardenable fluidic material is preferably provided at reduced operating pressures and flow rates during an end portion of the extruding. The non hardenable fluidic material is preferably injected below the mandrel. The method includes pressurizing a region of the tubular liner below the mandrel. The region of the tubular liner below the mandrel is preferably pressurized to pressures ranging from about 34.473 to 620.52813 bar (500 to 9,000 psi). The method preferably includes fluidically isolating an interior region of the tubular liner from an exterior region of the tubular liner. The method further preferably includes curing the hardenable sealing material, and removing at least a portion of the cured sealing material located within the tubular liner. The method further preferably includes overlapping the tubular liner with an existing wellbore casing. The method further preferably includes sealing the overlap between the tubular liner and the existing wellbore casing. The method further preferably includes supporting the extruded tubular liner using the overlap with the existing wellbore casing. The method further preferably includes testing the integrity of the seal in the overlap between the tubular liner and the existing wellbore casing. The method further preferably includes removing at least a portion of the hardenable fluidic sealing material within the tubular liner before curing. The method further preferably includes lubricating the surface of the mandrel. The method further preferably includes absorbing shock. The method further preferably includes catching the mandrel upon the completion of the extruding.

An apparatus for creating a casing in a borehole located in a subterranean formation has been described that includes a support member, a mandrel, a tubular member, and a shoe. The support member includes a first fluid passage. The mandrel is coupled to the support member and includes a second fluid passage. The tubular member is coupled to the mandrel. The shoe is coupled to the tubular liner and includes a third fluid passage. The first, second and third fluid passages are operably coupled. The support member preferably further includes a pressure relief passage, and a flow control valve coupled to the first fluid passage and the pressure relief passage. The support member further preferably includes a shock absorber. The support member preferably includes one or more sealing members adapted to prevent foreign material from entering an interior region of the tubular member. The mandrel is preferably expandable. The tubular member is preferably fabricated from materials selected from the group consisting of Oilfield Country Tubular Goods, 13 chromium steel tubing/casing, and plastic casing. The tubular member preferably has inner and outer diameters ranging from about 7.62 to 39.37 cms (3 to 15.5 inches) and 8.89 to 40.64 cms (3.5 to 16 inches), respectively. The tubular member preferably has a plastic yield point ranging from about 275.9028 to 9307.92195 bar (40,000 to 135,000 psi). The tubular member preferably includes one or more sealing members at an end portion. The tubular member preferably includes one or more pressure relief holes at an end portion. The tubular member preferably includes a catching member at an end portion for slowing down the mandrel. The shoe preferably includes an inlet port coupled to the third fluid passage, the inlet port adapted to receive a plug for blocking the inlet port. The shoe preferably is drillable.

A method of joining a second tubular member to a first tubular member, the first tubular member having an inner diameter greater than an outer diameter of the second tubular member, has been described that includes positioning a mandrel within an interior region of the second tubular member, positioning the first and second tubular members in an overlapping relationship, pressurizing a portion of the interior region of the second tubular member; and extruding the second tubular member off of the mandrel into engagement with the first tubular member. The pressurizing of the portion of the interior region of the second tubular member is preferably provided at operating pressures ranging from about

34.473 to 620.52813 bar (500 to 9,000 psi). The pressurizing of the portion of the interior region of the second tubular member is preferably provided at reduced operating pressures during a latter portion of the extruding. The method further preferably includes sealing the overlap between the first and second tubular members. The method further preferably includes supporting the extruded first tubular member using the overlap with the second tubular member. The method further preferably includes lubricating the surface of the mandrel. The method further preferably includes absorbing shock.

A liner for use in creating a new section of wellbore casing in a subterranean formation adjacent to an already existing section of wellbore casing has been described that includes an annular member. The annular member includes one or more sealing members at an end portion of the annular member, and one or more pressure relief passages at an end portion of the annular member.

A wellbore casing has been described that includes a tubular liner and an annular body of a cured fluidic sealing material. The tubular liner is formed by the process of extruding the tubular liner off of a mandrel. The tubular liner is preferably formed by the process of placing the tubular liner and mandrel within the wellbore, and pressurizing an interior portion of the tubular liner. The annular body of the cured fluidic sealing material is preferably formed by the process of injecting a body of hardenable fluidic sealing material into an annular region external of the tubular liner. During the pressurizing, the interior portion of the tubular liner is preferably fluidically isolated from an exterior portion of the tubular liner. The interior portion of the tubular liner is preferably pressurized to pressures ranging from about 34.473 to 620.52813 bar (500 to 9,000 psi). The tubular liner preferably overlaps with an existing wellbore casing. The wellbore casing preferably further includes a seal positioned in the overlap between the tubular liner and the existing wellbore casing. Tubular liner is preferably supported the overlap with the existing wellbore casing.

A method of repairing an existing section of a wellbore casing within a borehole has been described that includes installing a tubular liner and a mandrel within the wellbore casing, injecting a body of a fluidic material into the borehole, pressurizing a portion of an interior region of the tubular liner, and radially

expanding the liner in the borehole by extruding the liner off of the mandrel. In a preferred embodiment, the fluidic material is selected from the group consisting of slag mix, cement, drilling mud, and epoxy. In a preferred embodiment, the method further includes fluidically isolating an interior region of the tubular liner 5 from an exterior region of the tubular liner. In a preferred embodiment, the injecting of the body of fluidic material is provided at operating pressures and flow rates ranging from about 34.473 to 620.52813 bar (500 to 9,000 psi) and 151.4164 to 113562.355 litres/minute (40 to 3,000 gallons/min). In a preferred embodiment, the injecting of the body of fluidic material is provided at reduced operating pressures and flow rates during an end portion of the extruding.

10 In a preferred embodiment, the fluidic material is injected below the mandrel. In a preferred embodiment, a region of the tubular liner below the mandrel is pressurized. In a preferred embodiment, the region of the tubular liner below the mandrel is pressurized to pressures ranging from about 34.473 to 620.52813 bar (500 to 9,000 psi). In a preferred embodiment, the method further includes overlapping the tubular liner 15 with the existing wellbore casing. In a preferred embodiment, the method further includes sealing the interface between the tubular liner and the existing wellbore casing. In a preferred embodiment, the method further includes supporting the extruded tubular liner using the existing wellbore casing. In a preferred embodiment, the method further includes testing the integrity of the seal in th 20 interface between the tubular liner and the existing wellbore casing. In a preferred embodiment, method further includes lubricating the surface of th mandrel. In a preferred embodiment, the method further includes absorbing shock. In a preferred embodiment, the method further includes catching the mandrel upon the completion of the extruding. In a preferred embodiment, the 25 method further includes expanding the mandrel in a radial direction.

A tie-back liner for lining an existing wellbore casing has been described that includes a tubular liner and an annular body of a cured fluidic sealing material. The tubular liner is formed by the process of extruding the tubular liner off of a mandrel. The annular body of a cured fluidic sealing material is coupled 30 to the tubular liner. In a preferred embodiment, the tubular liner is formed by the process of placing the tubular liner and mandrel within the wellbore, and pressurizing an interior portion of the tubular liner. In a preferred embodiment,

during the pressurizing, the interior portion of the tubular liner is fluidically isolated from an exterior portion of the tubular liner. In a preferred embodiment, the interior portion of the tubular liner is pressurized at pressures ranging from about 34.473 to 620.52813 bar (500 to 9,000 psi). In a preferred embodiment, the annular body of a cured fluidic sealing material is formed by the process of injecting a body of hardenable fluidic sealing material into an annular region between the existing wellbore casing and the tubular liner. In a preferred embodiment, the tubular liner overlaps with another existing wellbore casing. In a preferred embodiment, the tie-back liner further includes a seal positioned in the overlap between the tubular liner and the other existing wellbore casing. In a preferred embodiment, tubular liner is supported by the overlap with the other existing wellbore casing.

An apparatus for expanding a tubular member has been described that includes a support member, a mandrel, a tubular member, and a shoe. The support member includes a first fluid passage. The mandrel is coupled to the support member. The mandrel includes a second fluid passage operably coupled to the first fluid passage, an interior portion, and an exterior portion. The interior portion of the mandrel is drillable. The tubular member is coupled to the mandrel. The shoe is coupled to the tubular member. The shoe includes a third fluid passage operably coupled to the second fluid passage, an interior portion, and an exterior portion. The interior portion of the shoe is drillable. Preferably, the interior portion of the mandrel includes a tubular member and a load bearing member. Preferably, the load bearing member comprises a drillable body. Preferably, the interior portion of the shoe includes a tubular member, and a load bearing member. Preferably, the load bearing member comprises a drillable body. Preferably, the exterior portion of the mandrel comprises an expansion cone. Preferably, the expansion cone is fabricated from materials selected from the group consisting of tool steel, titanium, and ceramic. Preferably, the expansion cone has a surface hardness ranging from about 58 to 62 Rockwell C. Preferably at least a portion of the apparatus is drillable.

Although illustrative embodiments of the invention have been shown and described, a wide range of modification, changes and substitution is contemplated in the foregoing disclosure. In some instances, some features of the present

1
The invention may be employed without a corresponding use of the other features. Accordingly, it is appropriate that the appended claims be construed broadly and in a manner consistent with the scope of the invention.

CLAIMS

1. A method of creating a casing in a borehole located in a subterranean formation, comprising:
 - 5 installing a tubular liner and a mandrel in the borehole;
 - injecting a fluidic material into the borehole;
 - injecting the fluidic material through the mandrel;
 - pressurizing a portion of an interior region of the tubular liner below the mandrel; and
 - 10 radially expanding at least a portion of the tubular liner in the borehole by extruding at least a portion of the tubular liner off of the mandrel.

2. A method of creating a casing in a borehole located in a section of a subterranean formation, the borehole having an already existing casing,
 - 15 comprising:
 - drilling out a new section of the borehole adjacent to the already existing casing;
 - placing a tubular liner and an expandable mandrel into the new section of the borehole;
 - 20 overlapping the tubular liner with the already existing casing;
 - injecting a hardenable fluidic sealing material into an annular region between the tubular liner and the new section of the borehole;
 - fluidically isolating the annular region between the tubular liner and the new section of the borehole from an interior region of the tubular liner below
 - 25 the mandrel;
 - injecting a non hardenable fluidic material into the interior region of the tubular liner below the mandrel;
 - extruding the tubular liner off of the expandable mandrel;
 - sealing the overlap between the tubular liner and the already existing
 - 30 casing;
 - supporting the tubular liner with the overlap with the already existing casing;

removing the mandrel from the borehole;
testing the integrity of the seal of the overlap between the tubular liner
and the already existing casing;
removing at least a portion of the hardenable fluidic sealing material
5 from the interior of the tubular liner;
curing the remaining portions of the hardenable fluidic sealing material;
and
removing at least a portion of the cured hardenable fluidic sealing
material within the tubular liner.

10

3. An apparatus, comprising:

a support member, the support member including a first fluid passage;
a mandrel coupled to the support member, the mandrel including:
a second fluid passage;
15 a tubular member coupled to the mandrel; and
a shoe coupled to the tubular member, the shoe including a third fluid
passage;
wherein the first, second and third fluid passages are operably coupled.

20

4. An apparatus, comprising:

a support member, the support member including:
a first fluid passage;
a second fluid passage; and
a flow control valve coupled to the first and second fluid passages;
25 an expandable mandrel coupled to the support member, the expandable
mandrel including a third fluid passage coupled to the first fluid passage;
a tubular member coupled to the mandrel, the tubular member including
one or more sealing elements;
a shoe coupled to the tubular member, the shoe including:
30 a fourth fluid passage coupled to the third fluid passage, the fourth fluid
passage adapted to receive a stop member; and

one or more exhaust passages coupled to the fourth fluid passage for injecting fluidic material outside of the shoe; and

at least one sealing member coupled to the support member, the sealing member adapted to prevent the entry of foreign material into an interior region
5 of the tubular member.

5. A method of joining a second tubular member to a first tubular member, the first tubular member having an inner diameter greater than an outer diameter of the second tubular member, comprising:

10 positioning a mandrel within an interior region of the second tubular member;

pressurizing a portion of the interior region of the second tubular member below the mandrel by injecting a fluidic material into the second tubular member through the mandrel; and

15 extruding the second tubular member off of the mandrel into engagement with the first tubular member.

6. An apparatus, comprising:

a support member including a first fluid passage;

20 a mandrel coupled to the support member, the mandrel including:
a second fluid passage operably coupled to the first fluid passage;

an interior portion; and

an exterior portion;

wherein the interior portion of the mandrel is drillable;

25 an expandable tubular member coupled to the mandrel; and

a shoe coupled to the tubular member, the shoe including:

a third fluid passage operably coupled to the second fluid passage;

an interior portion; and

an exterior portion;

30 wherein the interior portion of the shoe is drillable.

7. The method of claim 1, wherein the injecting includes:

injecting hardenable fluidic sealing material into an annular region located between the borehole and the exterior of the tubular liner; and

injecting non hardenable fluidic material into an interior region of the tubular liner below the mandrel.

5

8. The method of claim 7, further comprising:
fluidically isolating the annular region from the interior region before injecting the non hardenable fluidic material into the interior region.

10 9. The method of claim 7, wherein the injecting of the hardenable fluidic sealing material is provided at operating pressures and flow rates ranging from 0 to 344.738 bar (0 to 5,000 psi) and 0 to 5618.12 litres/min (0 to 1,500 gallons/min).

15 10. The method of claim 7, wherein the injecting of the non hardenable fluidic material is provided at operating pressures and flow rates ranging from 34.473 to 620.52813 bar (500 to 9,000 psi) and 151.4164 to 11356.2355 litres/min (40 to 3,000 gallons/min).

20 11. The method of claim 7, wherein the injecting of the non hardenable fluidic material is provided at reduced operating pressures and flow rates during an end portion of the extruding.

25 12. The method of claim 1, wherein the portion of the tubular liner below the mandrel is pressurized to pressures ranging from 34.473 to 620.52813 bar (500 to 9,000 psi).

30 13. The method of claim 1, further comprising:
fluidically isolating an interior region of the tubular liner from an exterior region of the tubular liner.

14. The method of claim 13, wherein the interior region of the tubular liner isolated from the region to the tubular liner by inserting one or more plugs into the injected fluidic material.

5 15. The method of claim 1, further comprising:
curing at least a portion of the fluidic material; and
removing at least a portion of the cured fluidic material located within
the tubular liner.

10 16. The method of claim 1, further comprising:
overlapping the tubular liner with an existing wellbore casing.

17. The method of claim 16, further comprising:
sealing the overlap between the tubular liner and the existing wellbore
15 casing.

18. The method of claim 17, further comprising:
supporting the extruded tubular liner using the overlap with the existing
wellbore casing.

20 19. The method of claim 17, further comprising:
testing the integrity of the seal in the overlap between the tubular liner
and the existing wellbore casing.

25 20. The method of claim 15, further comprising:
removing at least a portion of the hardenable fluidic sealing material
within the tubular liner before curing.

30 21. The method of claim 1, further comprising:
lubricating the surface of the mandrel.

22. The method of claim 1, further comprising:

absorbing shock.

23. The method of claim 1, further comprising:
catching the mandrel upon the completion of the extruding.

5

24. The method of claim 1, further comprising expanding the
mandrel in a radial direction.

25. The method of claim 1, further including:
drilling out the mandrel.

10

26. The method of claim 1, further including:
supporting the mandrel with coiled tubing.

15

27. The method of claim 1, wherein the wall thickness of the tubular
liner is variable.

20

28. The method of claim 1, wherein the mandrel is coupled to a
drillable shoe.

29. The apparatus of claim 3, wherein the support member further
includes:

a pressure relief passage; and

a flow control valve coupled to the first fluid passage and the pressure
relief passage.

25

30. The apparatus of claim 3, wherein the support member further
includes a shock absorber.

30

31. The apparatus of claim 3, wherein the support member includes
one or more sealing members adapted to prevent foreign material from entering
an interior region of the tubular member.

32. The apparatus of claim 3, wherein the support member includes one or more stabilizers.

5 33. The apparatus of claim 3, wherein the mandrel is expandable.

34. The apparatus of claim 3, wherein the tubular member is fabricated from materials selected from the group consisting of automotive grade steel, plastic and chromium steel.

10

35. The apparatus of claim 3, wherein the tubular member has inner and outer diameters ranging from 1.905 to 119.38 cms (0.75 to 47 inches) and 2.667 to 121.92 cms (1.05 to 48 inches), respectively.

15 36. The apparatus of claim 3, wherein the tubular member has a plastic yield point ranging from 275.9028 to 9307.92195 bar (40,000 to 135,000 psi).

37. The apparatus of claim 3, wherein the tubular member includes
20 one or more sealing members at an end portion.

38. The apparatus of claim 3, wherein the tubular member includes one or more pressure relief holes at an end portion.

25 39. The apparatus of claim 3, wherein the tubular member includes a catching member at an end portion for slowing down movement of the mandrel.

40. The apparatus of claim 3, wherein the shoe includes:
a fluid conduit coupled to the third fluid passage, the fluid conduit
30 adapted to receive a plug for blocking the fluid conduit.

41. The apparatus of claim 3, wherein the support member comprises coiled tubing.

42. The apparatus of claim 3, wherein the shoe includes one or more exhaust passages coupled to the third fluid passage for injecting fluidic material outside of the shoe.

43. The apparatus of claim 3, further comprising at least one wiper plug removably coupled to the mandrel.

10

44. The apparatus of claim 43, wherein the wiper plug includes a fluid passage operably coupled to the second fluid passage.

45. The apparatus of claim 3, wherein at least a portion of the mandrel and shoe are drillable.

15

46. The apparatus of claim 3, the wall thickness of the tubular member in an area adjacent to the mandrel is less than the wall thickness of the tubular member in an area that is not adjacent to the mandrel.

20

47. The method of claim 5, wherein the pressurizing of the portion of the interior region of the second tubular member is provided at operating pressures ranging from 34.473 to 620.52813 bar (500 to 9,000 psi).

48. The method of claim 5, wherein the pressurizing of the portion of the interior region of the second tubular member is provided at reduced operating pressures during a latter portion of the extruding.

25

49. The method of claim 5, further comprising:
sealing the interface between the first and second tubular members.

30

50. The method of claim 5, further comprising:

supporting the extruded second tubular member using the interface with the first tubular member.

5 51. The method of claim 5, further comprising:
lubricating the surface of the mandrel.

52. The method of claim 5, further comprising:
absorbing shock.

10 53. The method of claim 5, further comprising:
expanding the mandrel in a radial direction.

15 54. The method of claim 5, further comprising:
positioning the first and second tubular members in an overlapping
relationship.

20 55. The method of claim 5, further comprising:
fluidically isolating an interior region of the second tubular member from
an exterior region of the second tubular member.

25 56. The method of claim 55, wherein the interior region of the
second tubular member is fluidically isolated from the region exterior to the
second tubular member by injecting one or more plugs into the interior of the
second tubular member.

30 57. The method of claim 5, wherein the pressurizing of the portion of
the interior region of the second tubular member is provided by injecting a
fluidic material at operating pressures and flow rates ranging from 34.473 to
620.52813 bar (500 to 9,000 psi) and 151.4164 to 11356.2355 litres/minute (40
to 3,000 gallons/minute).

58. The method of claim 5, further comprising:

injecting fluidic material beyond the mandrel.

59. The method of claim 5, wherein the region of the tubular liner beyond the mandrel is pressurized to pressures ranging from 34.473 to 5 620.52813 bar (500 to 9,000 psi).

60. The method of claim 5, wherein the first tubular member comprises an existing section of wellbore.

10 61. The method of claim 5, further comprising:
supporting the extruded second tubular member using the first tubular member.

15 62. The method of claim 49, further comprising:
testing the integrity of the seal in the interface between the first tubular member and the second tubular member.

20 63. The method of claim 5, further comprising:
catching the mandrel upon the completion of the extruding.

64. The method of claim 5, further comprising:
drilling out the mandrel.

25 65. The method of claim 5, further comprising:
supporting the mandrel with coiled tubing.

66. The method of claim 5, further comprising:
coupling the mandrel to a drillable shoe.

30 67. The apparatus of claim 6, wherein the interior portion of the mandrel includes:
a tubular member; and

a load bearing member.

68. The apparatus of claim 67, wherein the load bearing member comprises a drillable body.

5

69. The apparatus of claim 6, wherein the interior portion of the shoe includes:

a tubular member; and
a load bearing member.

10

70. The apparatus of claim 69, wherein the load bearing member comprises a drillable body.

15

71. The apparatus of claim 6, wherein the exterior portion of the mandrel comprises an expansion cone.

20

72. The apparatus of claim 71, wherein the expansion cone is fabricated from materials selected from the group consisting of ceramic, tool steel, titanium and low alloy steel.

73. The apparatus of claim 71, wherein the expansion cone has a surface hardness ranging from about 58 to 62 Rockwell C.

25

74. The apparatus of claim 6, further comprising:
one or more wiper plugs coupled to the mandrel

75. The apparatus of claim 74, wherein the wiper plug includes a fluid passage fluidically coupled to the second fluid passage.

30

76. The apparatus of claim 6, wherein the support member comprises coiled tubing.

77. The method of claim 1, wherein the interface between the mandrel and the tubular liner is not fluid tight.

5 78. The method of claim 2, wherein the interface between the mandrel and the tubular liner is not fluid tight.

79. The apparatus of claim 4, wherein the interface between the tubular member and the expandable mandrel is not fluid tight.

10

80. The method of claim 5, wherein the interface between the second tubular member and the mandrel is not fluid tight.

15 81. The apparatus of claim 6, wherein the interface between the mandrel and the tubular member is not fluid tight.

82. An apparatus, comprising:
a support member defining a first fluid passage;
an expansion mandrel coupled to the support member including an outer
20 expansion surface and defining a second fluid passage;
a tubular liner coupled to the expansion mandrel; and
a shoe coupled to the tubular liner defining a third fluid passage;
wherein the first, second and third fluid passages are operably coupled;
and
25 wherein the interface between the tubular liner and the expansion
mandrel is not fluid tight.

83. The apparatus of claim 82, wherein the support member further includes a shock absorber.

30

84. The apparatus of claim 82, wherein the support member includes one or more sealing members adapted to prevent foreign material from entering an interior region of the tubular liner.

5 85. The apparatus of claim 82, wherein the support member includes one or more stabilizers.

86. The apparatus of claim 82, wherein the expansion mandrel is expandable.

10

87. The apparatus of claim 82, wherein the tubular liner is fabricated from materials selected from the group consisting of automotive grade steel, plastic and chromium steel.

15

88. The apparatus of claim 82, wherein the tubular liner has inner and outer diameters ranging from 1.905 to 119.38 cms (0.75 to 47 inches) and 2.667 to 121.92 cms (1.05 to 48 inches), respectively.

20 89. The apparatus of claim 82, wherein the tubular liner has a plastic yield point ranging from 275.9028 to 9307.92195 bar (40,000 to 135,000 psi).

90. The apparatus of claim 82, wherein the tubular liner includes one or more sealing members at an end portion.

25 91. The apparatus of claim 82, wherein the tubular liner includes one or more pressure relief holes at an end portion.

92. The apparatus of claim 82, wherein the tubular liner includes a catching member at an end portion for slowing down movement of the
30 expansion mandrel.

93. The apparatus of claim 82, wherein the shoe further defines an fluid conduit coupled to the third fluid passage, the fluid conduit adapted to receive a plug for blocking the fluid conduit.

5 94. The apparatus of claim 82, wherein the support member comprises coiled tubing.

95. The apparatus of claim 82, wherein the shoe includes one or more exhaust passages coupled to the third fluid passage for injecting fluidic material outside of the shoe.
10

96. The apparatus of claim 82, further comprising at least one wiper plug removably coupled to the expansion mandrel.

15 97. The apparatus of claim 96, wherein the wiper plug defines a fourth passage operably coupled to the second fluid passage.

98. The apparatus of claim 82, wherein at least a portion of the expansion mandrel and shoe are drillable.
20

99. The apparatus of claim 82, the wall thickness of the tubular liner in an area adjacent to the expansion mandrel is less than the wall thickness of the tubular liner in an area that is not adjacent to the expansion mandrel.

25 100. The apparatus of claim 82, wherein third fluid passage defined by the shoe comprises one or more radial passages defined by the shoe.

101. The apparatus of claim 82, further comprising a packer coupled to the shoe.
30

102. The apparatus of claim 82, wherein the wall thickness of a portion of the tubular liner above the expansion surface of the expansion

mandrel is greater than the wall thickness of a portion of the tubular liner below the expansion surface of the expansion mandrel.

103. An apparatus, comprising:

- 5 a support member defining a first fluid passage;
an expansion mandrel coupled to the support member including an outer expansion surface and defining a second fluid passage;
a tubular liner coupled to the expansion mandrel;
a shoe coupled to the tubular liner defining a third fluid passage; and
10 a packer coupled to the shoe;
wherein the first, second and third fluid passages are operably coupled.

104. An apparatus, comprising:

- 15 a support member defining a first fluid passage;
an expansion mandrel coupled to the support member including an outer expansion surface and defining a second fluid passage;
a tubular liner coupled to the expansion mandrel; and
a shoe coupled to the tubular liner defining a third fluid passage;
wherein the first, second and third fluid passages are operably coupled;
20 and
wherein the third fluid passage defined by the shoe comprises one or more radial passages.

105. An apparatus, comprising:

- 25 a support member defining a first fluid passage;
an expansion mandrel coupled to the support member including an outer expansion surface and defining a second fluid passage;
a tubular liner coupled to the expansion mandrel; and
a shoe coupled to the tubular liner defining a third fluid passage;
30 wherein the first, second and third fluid passages are operably coupled;
and

wherein the wall thickness of a portion of the tubular liner above the expansion surface of the expansion mandrel is greater than a wall thickness of a portion of the tubular liner below the expansion surface of the expansion mandrel.